

# Wall Mounted Reverse Osmosis Water Laboratory Tap 150mm

**LFP027**

Enware's Reverse Osmosis (RO) range is ideal for all pure water applications including distilled, demineralised or deionised water.

Water is recirculating constantly up to the point of draw off to ensure no dead leg within fittings. All internal waterways incorporate inert materials to ensure water supply purity, external brass construction is powder coated for durability.

## FEATURES

- Acetal internal construction to ensure water purity
- Fully recirculating fittings ensure no dead legs are created
- Brass external construction with protective powder coated finish
- Polypropylene ball valves for easier service and maintenance
- Tube Nozzle
- Ergonomic handle design for finger tip control
- Supplied with colour coded indication button on handle for media identification to DIN EN 13792 - specify media type when ordering
- Non-rising headwork with polymer seal
- Supplied with fixing kit

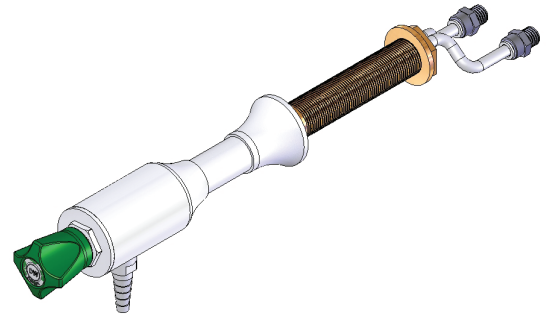

**NOTE:** Due to the essential closeness of the headworks to the outlet nozzle splashing may occur at some pressures. It is recommended that a short piece of removable tubing be fitted to the nozzle to prevent splashing

## Product Code

**LFP027** Wall Mounted Reverse Osmosis Water Lab Tap

## Options

**LFP026** Type 17 Reverse Osmosis Water Lab Tap Bench Mounted

## Technical Information

Connection	1/4" BSP
Mounting	3/4" BSP
Working Pressure Range	100-700kPa (water)
Diaphragm	500kPa Max Recommended
Maximum Testing Pressure	1000kPa
Working Temperature Range	0-50°C
Outlet Connection	Tube Nozzle

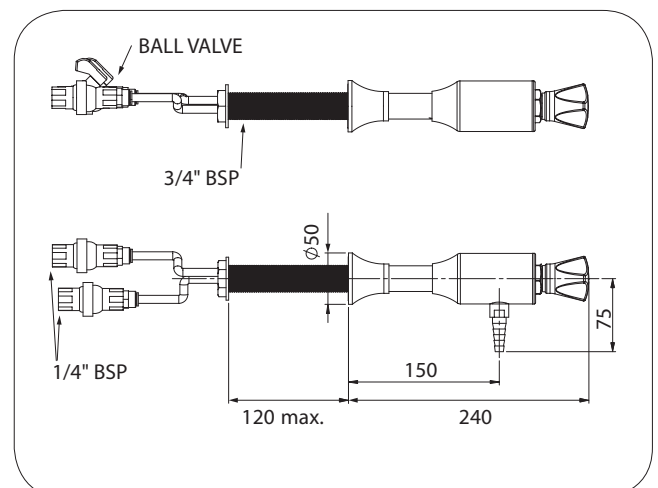

Version: Jun 20

Call 1300 369 273  
www.enware.com.au

Enware Australia Pty Limited  
9 Endeavour Rd Caringbah NSW 2229 Australia  
Ph: 02 8536 4000 info@enware.com.au



# Wall Mounted Reverse Osmosis Water Laboratory Tap 150mm

**LFPO27**

## R.O. WATER INSTALLATION

### Single Pipe Circulating System

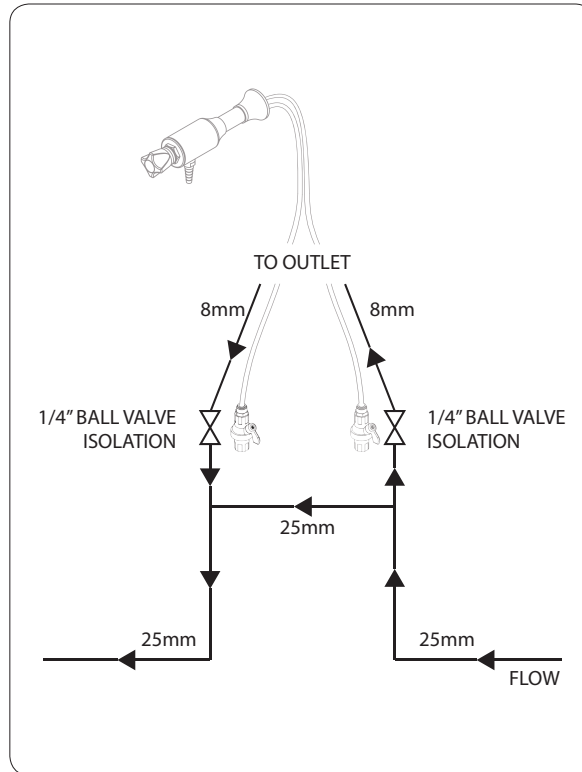

### Flow / Return Circulating System (Optimum Installation)

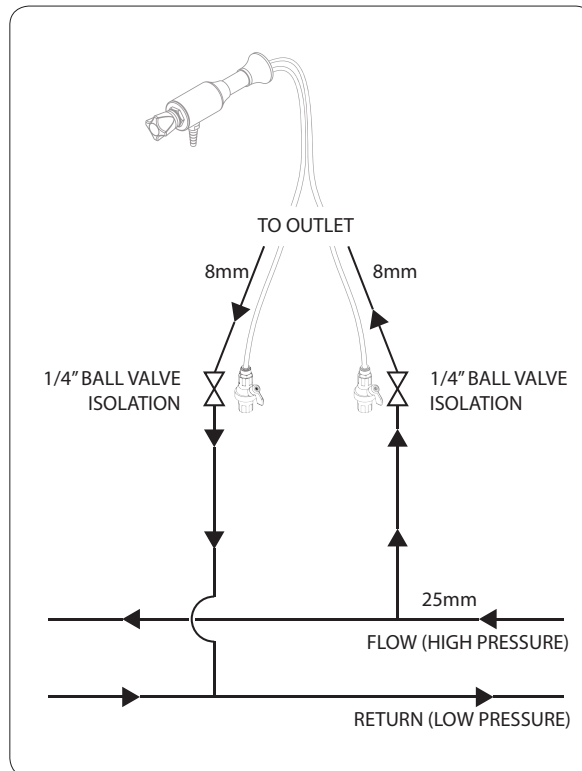

Version: Jun 20

Call 1300 369 273  
[www.enware.com.au](http://www.enware.com.au)

Enware Australia Pty Limited  
9 Endeavour Rd Caringbah NSW 2229 Australia  
Ph: 02 8536 4000 info@enware.com.au

