

CLIENT TO SPECIFY MEDIA TYPE

NOTE:  
SEALANT/SEALING METHOD MUST BE  
CHOSEN TO MATCH SPECIFIED MEDIA.

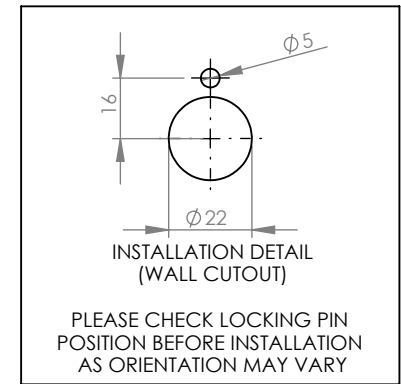
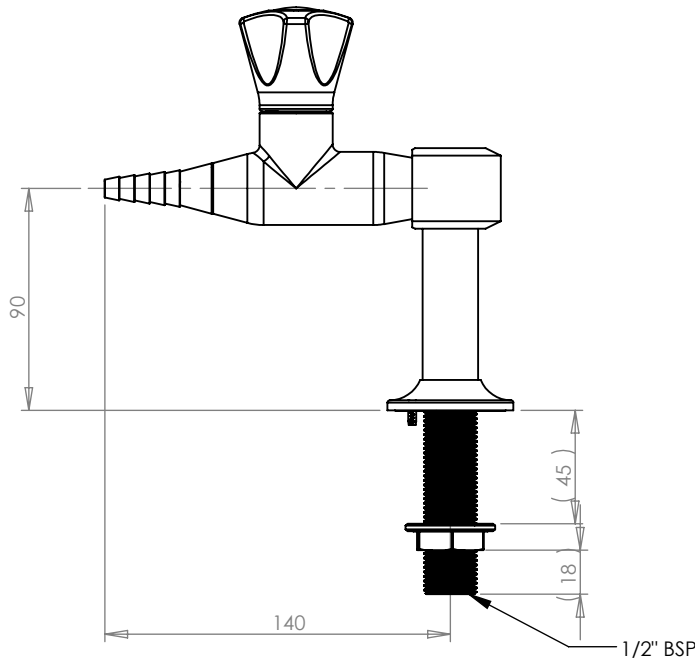
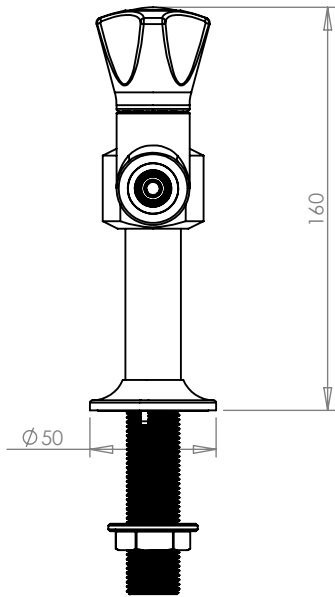
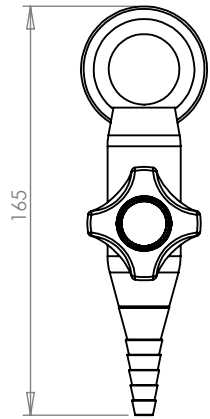
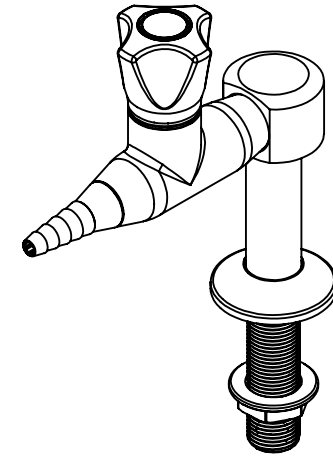

REV	DATE	CN	AMMENDMENTS	MODIFIED BY
A	6/9/11		FIRST ISSUE	
B	7/12/11		1/2" BSP WAS 1/2" BSP WITH 3/8" BSPF	
C	27/11/13	2309	671434 WAS 672418	YK

**GENERAL NOTES:**  
REMOVE ALL BURRS AND SHARP EDGES UNLESS OTHERWISE STATED  
DIMENSIONS ARE IN mm's

**TOLERANCE EXCEPT WHERE STATED:**

NO DECIMAL POINT    ∕ 0.2  
ONE DECIMAL PLACE   ∕ 0.1  
TWO DECIMAL PLACES ∕ 0.05  
ANGLES                 ∕ 1

DRAWN	AC	9 Endeavour Rd, Caringbah, NSW, 2229 Ph. 61-2-9525-9511 Fax. 61-2-9524-8421		
CHECKED	AC			
APPROVED	ENW			
TITLE: <b>1 WAY BENCH LCN ND</b>			Scale: Not To Scale	
MATERIAL:				
FINISH:				
This drawing is the Copyright of Enware Australia Pty Ltd and may not be reproduced in full or part without the written consent of Enware Australia Pty Ltd			DWG NO. <b>LCN145N</b> SHEET 1 OF 3	