

CLIENT TO SPECIFY MEDIA TYPE

NOTE:
SEALANT/SEALING METHOD MUST BE
CHOSEN TO MATCH SPECIFIED MEDIA.

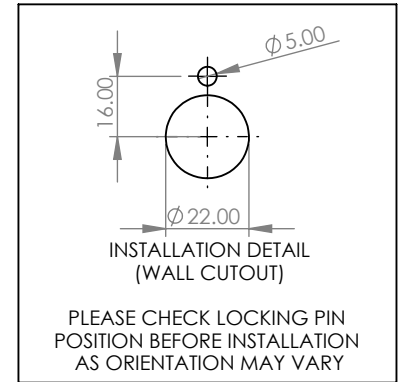
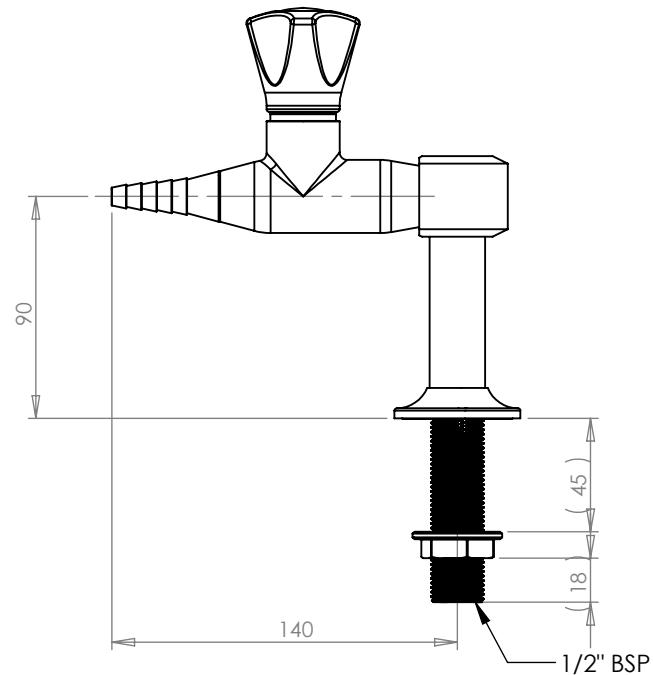
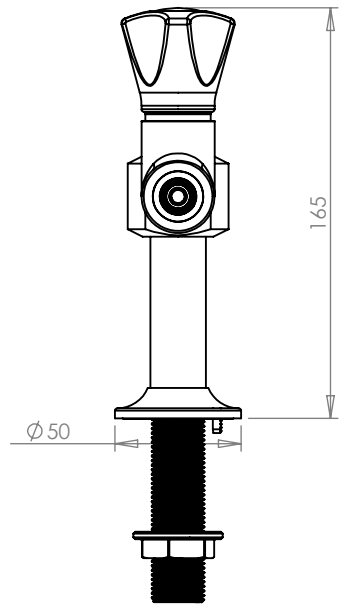
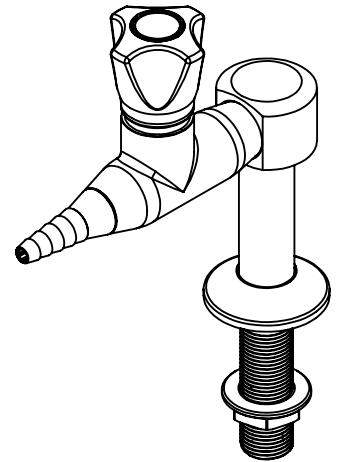

REV	DATE	CN	AMMENDMENTS	MODIFIED BY
A	6/9/11		FIRST ISSUE	
B	7/12/11		1/2" BSP WAS 1/2" BSP WITH 3/8" BSPF	

GENERAL NOTES:
REMOVE ALL BURRS AND SHARP EDGES UNLESS OTHERWISE STATED
DIMENSIONS ARE IN mm's

TOLERANCE EXCEPT WHERE STATED:

NO DECIMAL POINT ∕ 0.2
ONE DECIMAL PLACE ∕ 0.1
TWO DECIMAL PLACES ∕ 0.05
ANGLES ∕ 1

DRAWN	AC	9 Endeavour Rd, Caringbah, NSW, 2229 Ph. 61-2-9525-9511 Fax. 61-2-9524-8421		
CHECKED	AC			
APPROVED	ENW			
TITLE: 1WAY BENCH LCN PT				
Scale: Not To Scale				
MATERIAL:				
FINISH:				
This drawing is the Copyright of Enware Australia Pty Ltd and may not be reproduced in full or part without the written consent of Enware Australia Pty Ltd				
			DWG NO.	SHEET 1 OF 3
			LCN145B	