

CLIENT TO SPECIFY MEDIA TYPE

NOTE:
TAIL AND BASE TO BE SUPPLIED LOOSE.
CLIENT TO SEAL TAIL AND LOCK BASE TO THREAD AS REQUIRED.
SEALANT MUST BE CHOSEN TO MATCH SPECIFIED MEDIA.

REVISION				
REV.	DATE	ECN	DESCRIPTION	MODIFIED BY
A	01/06/11		FIRST ISSUE	
B	27/11/13	2309	671434 WAS 672418	YK
C	12/11/14	3893	887093 WAS 894093	TD

GENERAL NOTES:
 - REMOVE ALL BURRS AND SHARP EDGES UNLESS OTHERWISE STATED
 - ALL THREADS TO BE CHAMFERED
 - DIMENSIONS ARE IN mm's
 - DO NOT SCALE OFF DIMENSIONS

TOLERANCE EXCEPT WHERE STATED:
 NO DECIMAL POINT ∇ 2
 ONE DECIMAL PLACE ∇ 1
 ANGLES ∇ 1°

ENWARE RESERVES THE RIGHT TO AMMEND PRODUCT SPECIFICATIONS AND DESIGNS WITHOUT NOTICE

DRAWN	AC
CHECKED	YK
APPROVED	CL

This drawing is the property of Enware Australia Pty Ltd and may not be reproduced in full or part without the written consent of Enware Australia.



9 Endeavour Rd,
Caringbah, NSW, 2229
Ph. 61-2-9525-9511
Fax. 61-2-9524-8421

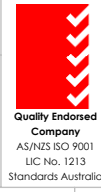

TITLE W'MNT STRAIGHT ND VLV W/ISO	
DRAWING NUMBER: LCN142WNI	
FINISH: POWDERCOATED WHITE	
SIZE: A4	SCALE: 1:2
SHEET: 1 OF 3	

A

B

C

D

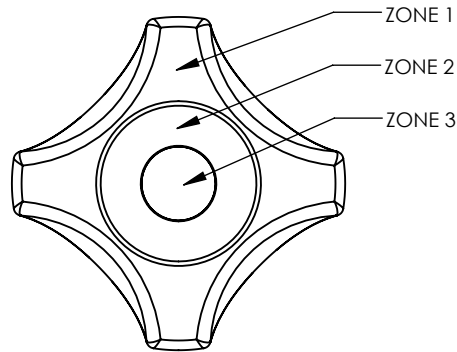
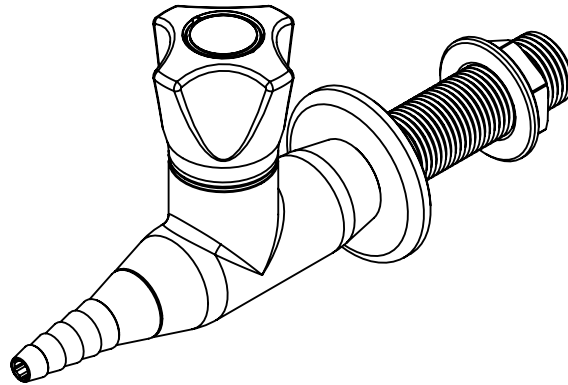

CLIENT TO SPECIFY MEDIA TYPE

COLOUR CHART

MEDIA	SALES CODE	SALES CODE	SALES CODE	SALES CODE	ZONE 1	ZONE 2	ZONE 3
WATER							
	CERAMIC VALVE	CERAMIC VALVE WITH ISOLATION VALVE	NEEDLE VALVE	NEEDLE VALVE WITH ISOLATION VALVE			
COLD WATER	LCN142WCWH2O	LCN142WICWH2O	LCN142WNCWH2O	LCN142WNICWH2O	GREEN	GREEN	BLUE
HOT WATER	LCN142WHWH2O	LCN142WIHWH2O	LCN142WNHWH2O	LCN142WNIHWH2O	GREEN	GREEN	RED
CHILLED WATER	LCN142WCHH2O	LCN142WICHH2O	LCN142WNCCHH2O	LCN142WNICHH2O	GREEN	BLUE	BLUE
GAS							
			NEEDLE VALVE	NEEDLE VALVE WITH ISOLATION VALVE			
ARGON	-	-	LCN142WNAR	LCN142WNIAR	BLUE	GREY	GREY
CARBOGEN	-	-	LCN142WNCB	LCN142WNICB	BLUE	BLACK	BLUE
CARBON DIOXIDE	-	-	LCN142WNCO2	LCN142WNICO2	BLUE	BLUE	BLACK
COMPRESS AIR	-	-	LCN142WNAIR	LCN142WNIAIR	BLUE	BLUE	YELLOW
HELIUM	-	-	LCN142WNHE	LCN142WNIHE	BLUE	GREY	WHITE
HYDROGEN	-	-	LCN142WNH2	LCN142WNIH2	RED	RED	RED
NITROGEN	-	-	LCN142WNN2	LCN142WNNIN2	BLUE	GREEN	GREEN
NITROUS OXIDE	-	-	LCN142WNN2O	LCN142WNNIN2O	BLUE	GREEN	BLUE
OXYGEN	-	-	LCN142WNO2	LCN142WNI02	BLUE	BLUE	BLUE
VACUUM	-	-	LCN142WNVAC	LCN142WNIIVAC	GREY	GREY	GREY
BURNING GASES							
	PUSH TO TURN CERAMIC	PUSH TO TURN CERAMIC WITH ISOLATION VALVE	NEEDLE VALVE	NEEDLE VALVE WITH ISOLATION VALVE			
ACETYLENE	LCN142WBC2H2	LCN142WBIC2H2	LCN142WNC2H2	LCN142WNIC2H2	YELLOW	WHITE	GREEN
PROPYLENE	LCN142WBC4H10	LCN142WBIC4H10	LCN142WNC3H6	LCN142WNIC3H6	YELLOW	BLUE	BLUE
ETHENE	LCN142WBC2H4	LCN142WBIC2H4	LCN142WNC2H4	LCN142WNIC2H4	YELLOW	BLACK	GREEN
METHANE	LCN142WBCH4	LCN142WBICH4	LCN142WNCCH4	LCN142WNICCH4	YELLOW	BLUE	YELLOW
OUTLET GAS (LPG)	LCN142WBGAS	LCN142WBIGAS	LCN142WNGAS	LCN142WNIIGAS	YELLOW	YELLOW	YELLOW

GENERAL NOTES:

- REMOVE ALL BURRS AND SHARP EDGES UNLESS OTHERWISE STATED
- ALL THREADS TO BE CHAMFERED
- DIMENSIONS ARE IN mm's
- DO NOT SCALE OFF DIMENSIONS

TOLERANCE EXCEPT WHERE STATED:

- NO DECIMAL POINT $\nabla 2$
- ONE DECIMAL PLACE $\nabla 1$
- ANGLES $\nabla 1^\circ$

ENWARE RESERVES THE RIGHT TO AMMEND PRODUCT SPECIFICATIONS AND DESIGNS WITHOUT NOTICE

DRAWN	AC
CHECKED	YK
APPROVED	CL



This drawing is the property of Enware Australia Pty Ltd and may not be reproduced in full or part without the written consent of Enware Australia.

9 Endeavour Rd,
Caringbah, NSW, 2229
Ph. 61-2-9525-9511
Fax. 61-2-9524-8421



TITLE
W'MNT STRAIGHT ND VLV W/ISO

DRAWING NUMBER: **LCN142WNI**

FINISH: POWDERCOATED WHITE

SIZE: A4

SCALE: 1:2

SHEET: 3 OF 3

REVISION

REV.	DATE	ECN	DESCRIPTION	MODIFIED BY
A	01/06/11		FIRST ISSUE	
B	27/11/13	2309	671434 WAS 672418	YK
C	12/11/14	3893	887093 WAS 894093	TD

A

B

C

D