

CLIENT TO SPECIFY MEDIA TYPE

NOTE:
SEALANT/SEALING METHOD MUST BE
CHOSEN TO MATCH SPECIFIED MEDIA.

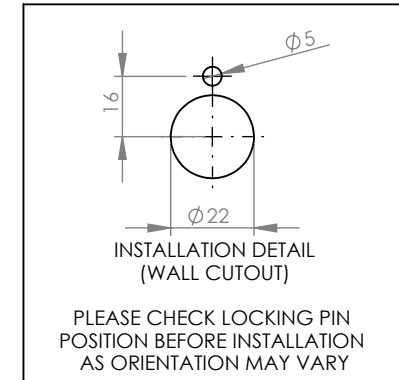
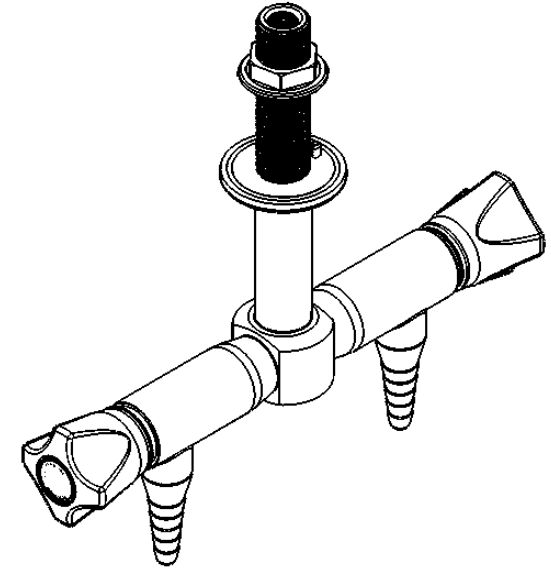
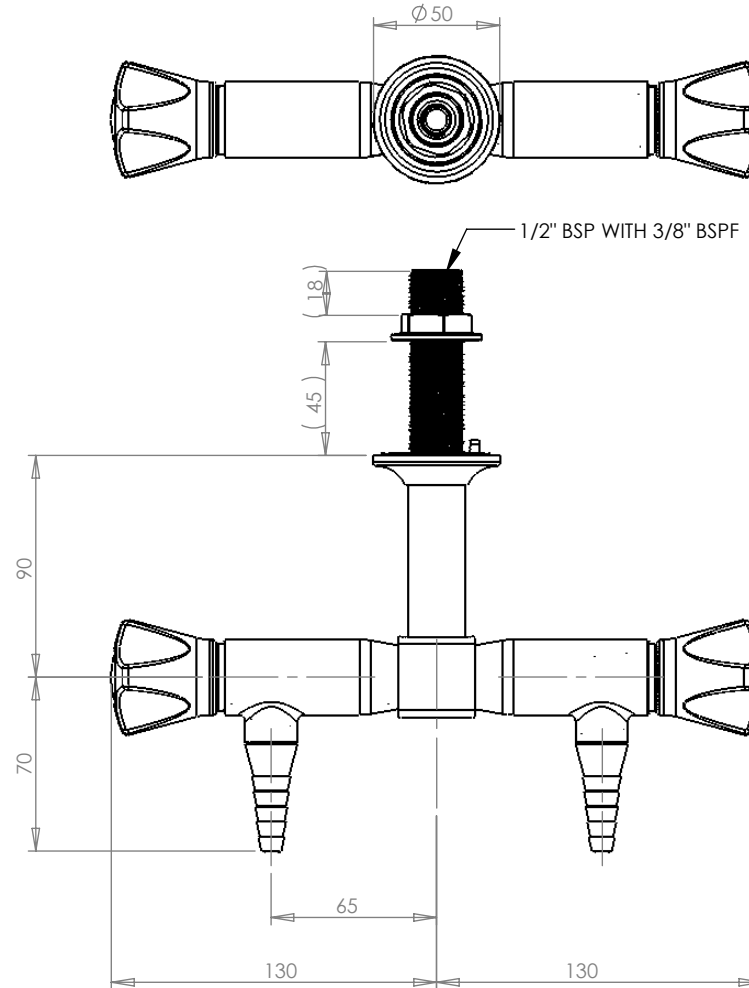
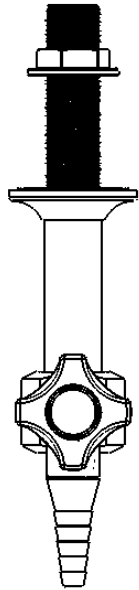

REV	DATE	CN	AMENDMENTS	MODIFIED BY
A	9/10/11		FIRST ISSUE	

GENERAL NOTES:
REMOVE ALL BURRS AND SHARP EDGES UNLESS OTHERWISE STATED
DIMENSIONS ARE IN mm's

TOLERANCE EXCEPT WHERE STATED:

NO DECIMAL POINT ∇ 0.2
ONE DECIMAL PLACE ∇ 0.1
TWO DECIMAL PLACES ∇ 0.05
ANGLES ∇ 1

ENWARE RESERVES THE RIGHT TO AMEND PRODUCT SPECIFICATIONS AND DESIGNS WITHOUT NOTICE.

DRAWN	AC	9 Endeavour Rd, Caringbah, NSW, 2229		
CHECKED		Ph. 61-2-9525-9511		
APPROVED		Fax. 61-2-9524-8421		
TITLE: 2WAY PENDANT PTT LCN				
Scale: Not To Scale			Scale: Not To Scale	
MATERIAL:				
FINISH:				
This drawing is the Copyright of Enware Australia Pty Ltd and may not be reproduced in full or part without the written consent of Enware Australia Pty Ltd				
DWG NO.			SHEET 1 OF 3	
LCN119B				