

④
CLOSED POSITION

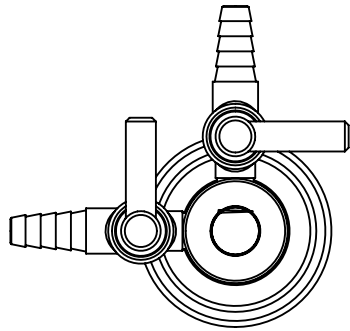

④
OPEN POSITION

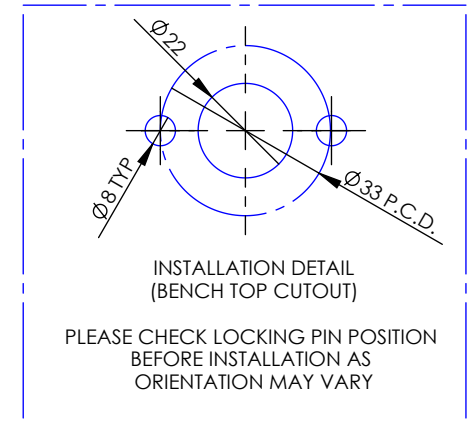
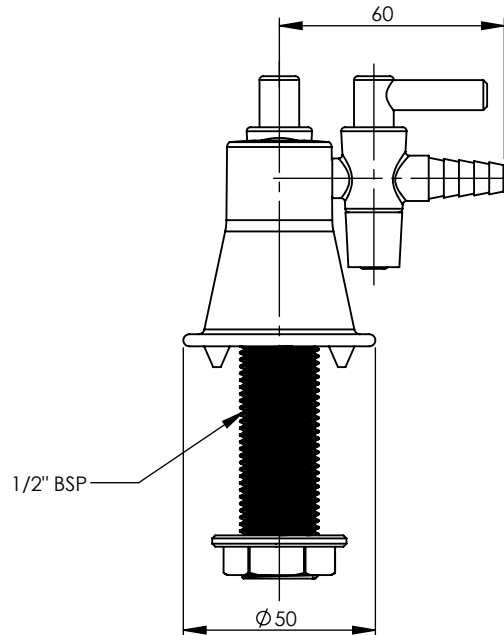
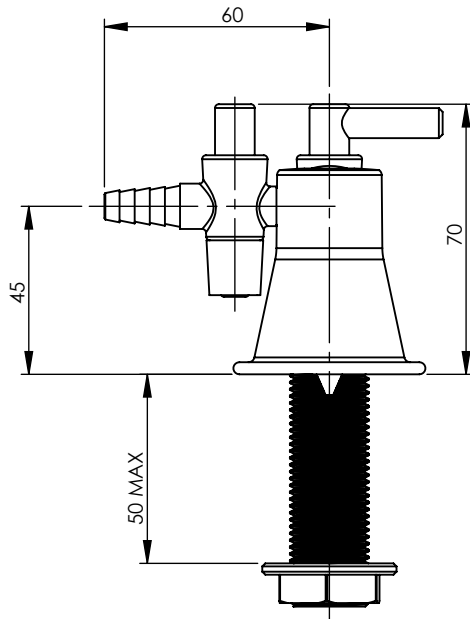
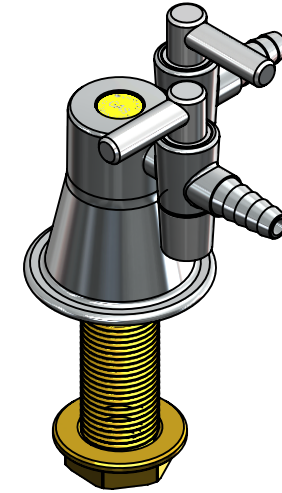
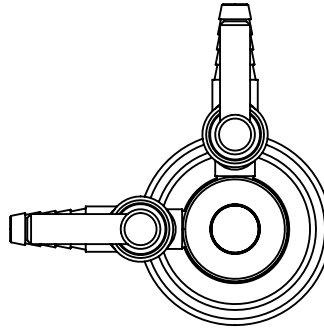

REVISION

REV.	DATE	ECN	DESCRIPTION	MODIFIED BY
A	12/01/06		DRAWN IN SOLIDWORK	
B	10/11/06		REDRAWN AND REASSEMBLE	
C	24/02/09		3/8" BSP INTERNAL ADDED	SM
D	20/07/11		ADDED CLOSED , OPEN VIEWS ON DRAWING	EK
E	13/01/15	4563	3/8" BSP INTERNAL DELETED. ADDED P/N 671333 TO BOM	TD

GENERAL NOTES:

- REMOVE ALL BURRS AND SHARP EDGES UNLESS OTHERWISE STATED
- ALL THREADS TO BE CHAMFERED
- DIMENSIONS ARE IN mm's
- DO NOT SCALE OFF DIMENSIONS

TOLERANCE EXCEPT WHERE STATED:

- NO DECIMAL POINT $\nabla 2$
- ONE DECIMAL PLACE $\nabla 1$
- ANGLES $\nabla 1^\circ$

ENWARE RESERVES THE RIGHT TO AMMEND PRODUCT SPECIFICATIONS AND DESIGNS WITHOUT NOTICE

DRAWN	KN
CHECKED	YK
APPROVED	LR



This drawing is the property of Enware Australia Pty Ltd and may not be reproduced in full or part without the written consent of Enware Australia.



9 Endeavour Rd,
Caringbah, NSW, 2229
Ph. 61-2-9525-9511
Fax. 61-2-9524-8421



TITLE
T40 2 2WAY GAS 90 MI 15 7KPA

DRAWING NUMBER: **LF125**

FINISH: CHROME PLATED

SIZE: A4 SCALE: 1:2 SHEET: 1 OF 2