

ITEM NO.	PART NUMBER	DESCRIPTION	QTY.
1	790150	SUB LF118S T26 PWD BENCH BIB A/V AER VP	1

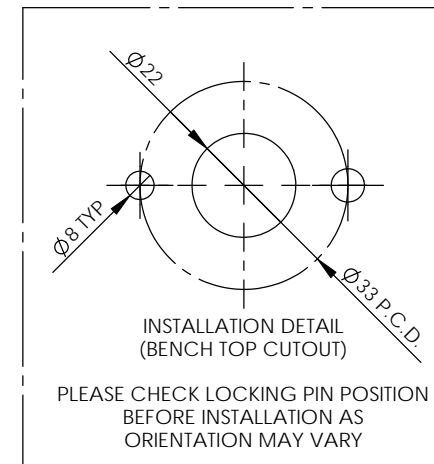
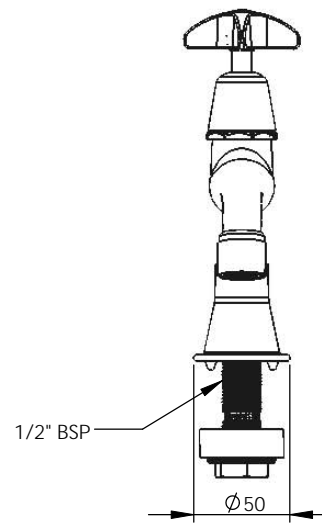
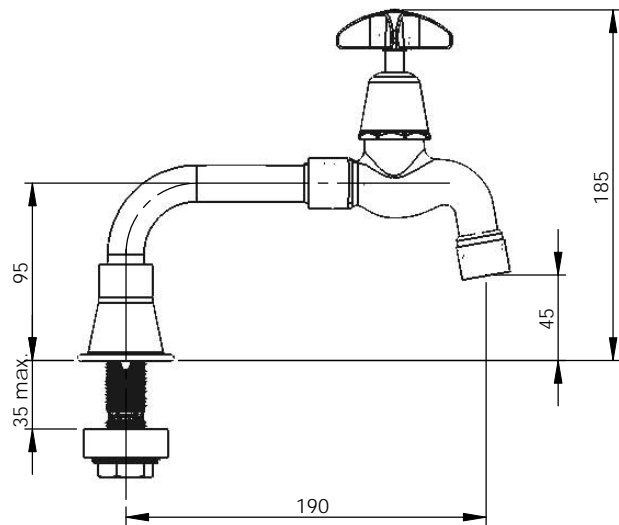
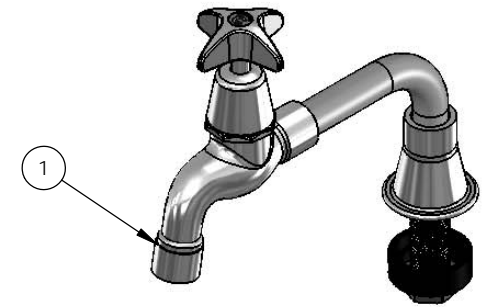
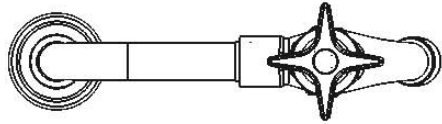

REV	DATE	CN	AMMENDMENTS	APP
A	01/11/06		FIRST ISSUE	
B	13/12/06		881609 MODIFIED, 881116 ADDED (B)	
C	03/12/09		BOM CHANGED, DIM CHANGED, NOW MEASURED FROM CENTRE OF OUTLET	KN

**GENERAL NOTES:**  
 REMOVE ALL BURRS AND SHARP EDGES UNLESS OTHERWISE STATED  
 DIMENSIONS ARE IN mm's  
**TOLERANCE EXCEPT WHERE STATED:**  
 NO DECIMAL POINT  $\pm 0.2$   
 ONE DECIMAL PLACE  $\pm 0.1$   
 TWO DECIMAL PLACES  $\pm 0.05$   
 ANGLES  $\pm 1$

ENWARE RESERVES THE RIGHT TO AMEND PRODUCT SPECIFICATIONS AND DESIGNS WITHOUT NOTICE.

DRAWN	KN	9 Endeavour Rd, Caringbah, NSW, 2229 Ph. 61-2-9525-9511 Fax. 61-2-9524-8421	
CHECKED			
APPROVED			
TITLE: T26 PWD BENCH BIB A/V AER VP 6LPM			
Scale: Not To Scale		Scale: Not To Scale	
MATERIAL:			
FINISH: CHROME PLATED			
This drawing is the Copyright of Enware Australia Pty Ltd and may not be reproduced in full or part without the written consent of Enware Australia Pty Ltd		DWG NO.	SHEET 1 OF 1
		LF118S	