

School Pattern Type 19 Mixing Set Swivel Outlet

LF113

A hob mounted laboratory mixer tap with Swivel spout and tube nozzle.

Features:

- High quality construction with durable chrome plating
- Vandal resistant school pattern or CS handle
- Comprehensive 12-month warranty
- Serviceable with all wearing components replaceable, thus providing an even longer life
- Made in Australia
- WELS 3 Star (8 lpm) water efficiency rating supplied as standard. Also available in 2 (9.5 lpm) and 5 (6 lpm) Star ratings

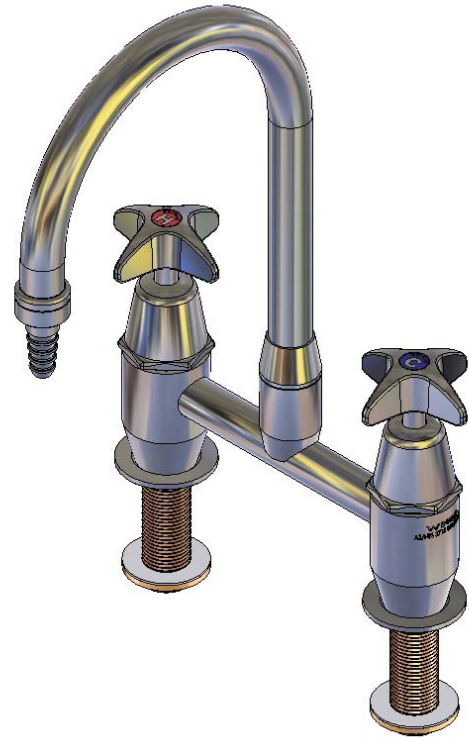

Product Codes

LF113	School Pattern Jumper Valve
LFQ113	School Pattern 1/4 Turn Ceramic Disc

Options:

- CS handle - refer to LCS
- Epoxy coating - specify when ordering
- Outlet attachments - aerated, anti-vandal aerator contact Enware for more information
- Alternate spout sizes - contact Enware for more information

Technical Information

Working Pressure Range Ceramic Disc	50-800kPa 500kPa Max (PCA)*
Working Pressure Range Jumper Valve	30-1200kPa 500kPa Max (PCA)*
Maximum Working Temperature*	Ceramic Disc - 85°C Jumper Valve - 95°C

*Enware products are to be installed in accordance with AS/NZS3500. Heated Water Supply AS/NZS 3500.4: For all sanitary fixtures used primarily for personal hygiene purposes are to deliver heated water not exceeding:
 a) 45°C for early childhood centres, primary and secondary schools and nursing homes or similar facilities for young, aged care, sick people with disabilities (43.5°C - NSW Code of Plumbing Practice)
 b) 50°C in all other buildings

NOTE: Enware Australia advises -
 1. Due to ongoing Research and Development, specifications may change without notice.
 2. Component specifications may change on some export models.

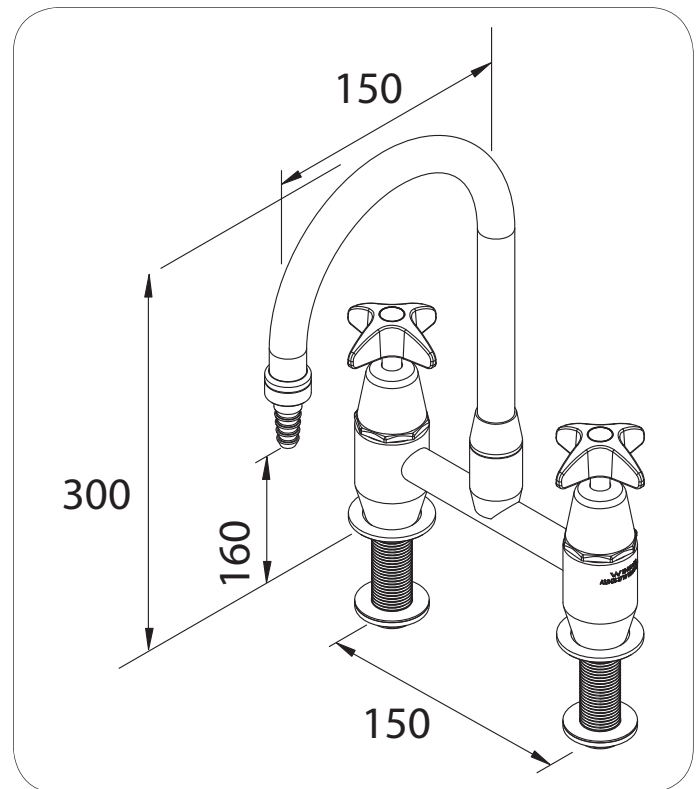
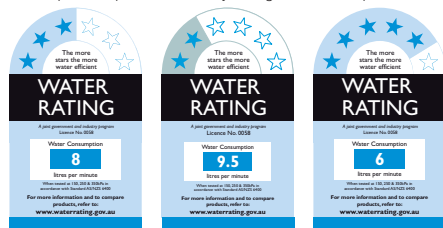

Version: AUG13

Call 1300 369 273
www.enware.com

Enware Australia Pty Limited
 9 Endeavour Rd Caringbah NSW 2229 Australia
 Ph: +61 2 8556 4000 Fax: +61 2 8556 4055

