

A

B

C

D

1

1

2

2

3

3

4

4

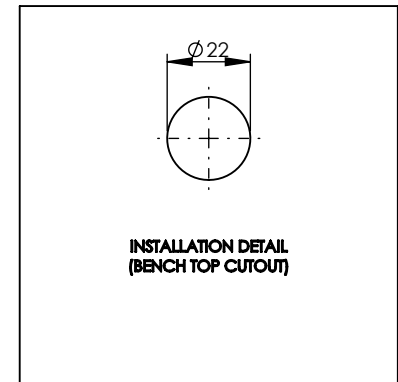
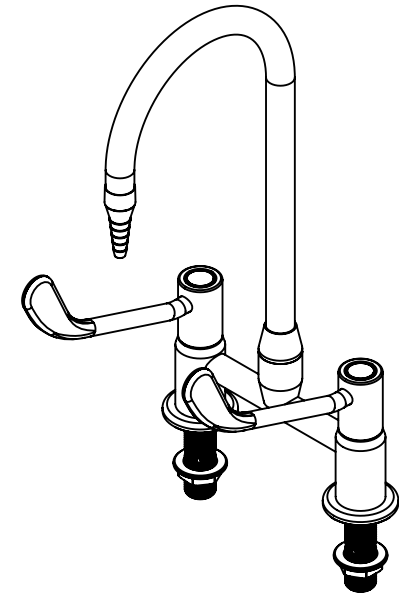
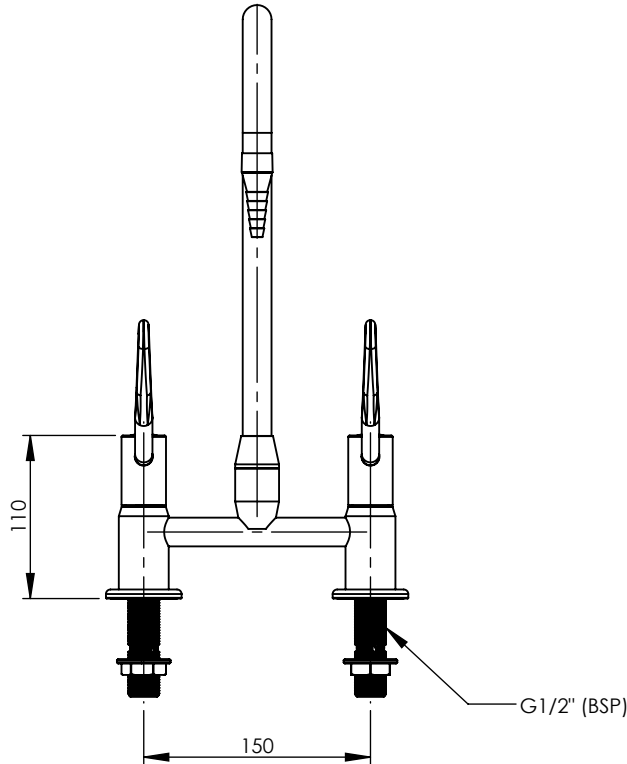
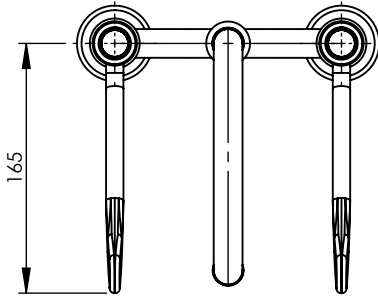
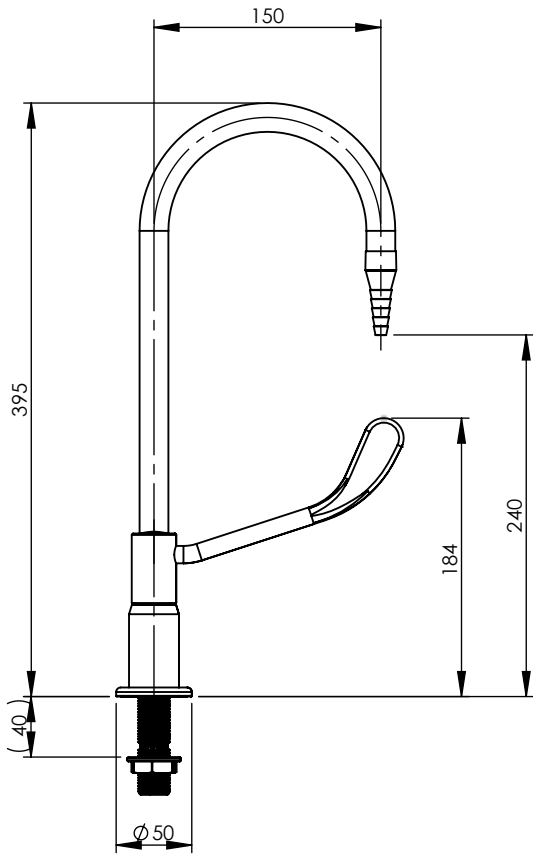

**Quality Endorsed Company**  
 AS/NZS ISO 9001  
 LIC No. 1213  
 Standards Australia  
 ENWARE RESERVES THE RIGHT TO AMMEND PRODUCT SPECIFICATIONS AND DESIGNS WITHOUT NOTICE

**GENERAL NOTES:**  
 - DIMENSIONS ARE IN mm's  
 - DO NOT SCALE OFF DIMENSIONS  
 - TAPWARE TOLERANCE  $\pm 2$  (EXCEPT WHERE STATED )  
 - SAFETY SANITARY AND CARE TOLERANCE  $\pm 5$  (EXCEPT WHERE STATED )

This drawing is the property of Enware Australia Pty Ltd and may not be reproduced in full or part without the written consent of Enware Australia.

DRAWN	YK
CHECKED	AK
APPROVED	LR

**ENWARE**

9 Endeavour Rd,  
 Caringbah, NSW, 2229  
 Ph. +61 2 8536 4000  
 Fax. +61 2 8556 4055

<b>DRAWING NUMBER:</b>	<b>LCN113L</b>	REV	<b>D.00</b>
<b>TITLE:</b>			
<b>T19 150MM LEVER MIX SET SWL O'LET</b>			
FINISH: POWDERCOATED WHITE	SIZE: A4	SCALE: 1:5	

A

B

C

D