

# Slimline 2 Way Right Angle Bench Mounted Laboratory Tap

## LCN102

Enware's Slimline laboratory outlets are supplied with a tapered tube nozzle and are assembled for each specific media type.

The durable powder coat finish gives significant protection against corrosion, discolouration and surface damage.

Slimline handles are ergonomically designed for precise feel and finger tip control. Handles are colour coded for easy service identification and use complimentary buttons.

### FEATURES

- WaterMark approved to AS/NZS 3718
- AS/NZS6400 compliant for WELS water efficiency
- Ceramic disc (¾ turn) or needle valve headworks
- Durable powder coat finish
- Handles and indicator button to suit specified media
- ½" BSP male inlet tail
- Fixing kit (backnut and antirotation pin)
- Tube nozzle with flow control and dual check valves
- Optional integral isolation/service valve

### Additional Options

- Finishes - Durable white powder coat (standard), bright chrome or alternate powder coat colouring
- Spout sizes - see Spout Options or contact Enware for custom sizing
- Outlet attachment options include: 45° tube nozzle, Aerator, Laminar flow, Thread attachments, Vacuum siphon - refer to Outlet Options or contact Enware for more information
- Alternate flow rates and water efficiency ratings available

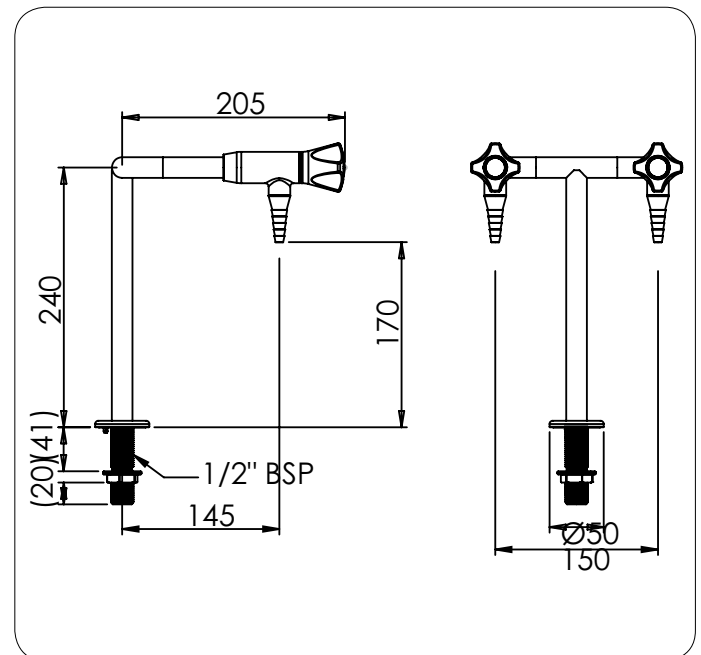

### Product Code

<b>LCN102</b>	Ceramic Disc - Water Only
<b>LCN102I</b>	Ceramic Disc with Isolation Valve
<b>LCN102N</b>	Needle Valve - Water Only
<b>LCN102NI</b>	Needle Valve with Isolation Valve - Water Only

### Technical Information

Connection	½" BSP Male
Working Pressure Range Ceramic Disc	20-700kPa (water) 500kPa Max (PCA)*
Working Pressure Range Needle Valve	1-700kPa (water) 500kPa Max (PCA)*
Maximum Testing Pressure	1000kPa
Working Temperature Range -	0-90°C
Outlet Connection	Tube Nozzle
	3/8" BSP Female (without nozzle) Other options available
Water Options	Cold, Hot and Chilled Water <i>NOTE: Client to specify media type</i>



\* Enware tapware must be installed in accordance with the provisions of, AS/NZS3500 and any relevant local regulations. Installations not complying with AS/NZS3500 may void the product and performance warranty provisions.

Version: MAR12

Call 1300 369 273

[www.enware.com.au](http://www.enware.com.au)

Enware Australia Pty Limited  
9 Endeavour Rd Caringbah NSW 2229 Australia  
Ph: 1300 369 273 Fax: 02 8556 4055

