

A

B

C

D

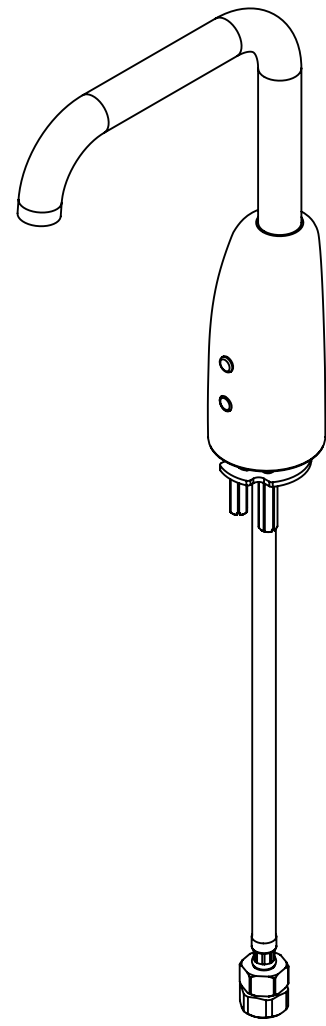
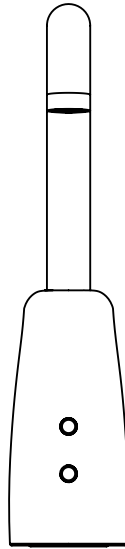
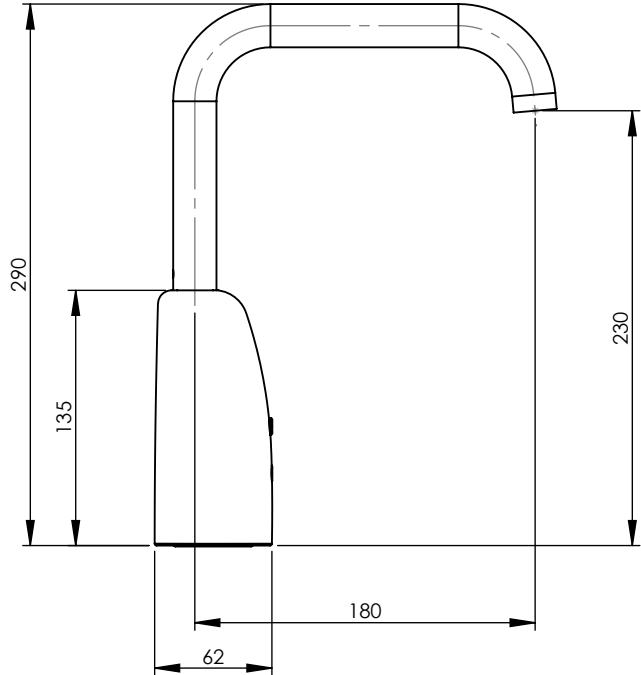
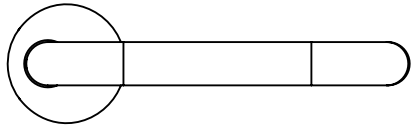

GENERAL NOTES:
 - REMOVE ALL BURRS AND SHARP EDGES UNLESS OTHERWISE STATED
 - ALL THREADS TO BE CHAMFERED
 - DIMENSIONS ARE IN mm's
 - DO NOT SCALE OFF DIMENSIONS

TOLERANCE EXCEPT WHERE STATED:
 NO DECIMAL POINT ∕ 2
 ONE DECIMAL PLACE ∕ 1
 ANGLES ∕ 1°

ENWARE RESERVES THE RIGHT TO AMMEND PRODUCT SPECIFICATIONS AND DESIGNS WITHOUT NOTICE

DRAWN	YK
CHECKED	CL
APPROVED	LR



This drawing is the property of Enware Australia Pty Ltd and may not be reproduced in full or part without the written consent of Enware Australia.



9 Endeavour Rd,
 Caringbah, NSW, 2229
 Ph. 61-2-9525-9511
 Fax. 61-2-9524-8421

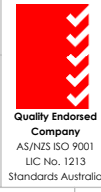

TITLE
ELECTRA S/TAP 170MM BATT
1TEMP 6STR 5.5L

DRAWING NUMBER: ENM6350

FINISH: CHROME PLATED

SIZE: A4 SCALE: 1:4 SHEET: 1 OF 2

REVISION

REV.	DATE	ECN	DESCRIPTION	MODIFIED BY
A	4/02/15		FIRST ISSUE	

A

B

C

D

1

1

2

2

3

3

4

4