

Bottle Filler Retrofit Suitable for Wallsend Trough With a Lid - Lever Activation

Installation and Maintenance Instructions

BUBBFRWEL-LL

BUBBFRWEL-LR



I00395_Jan 21

Call 1300 369 273
www.enware.com.au

Enware Australia Pty Limited
9 Endeavour Rd Caringbah NSW 2229 Australia
Ph: 02 8536 4000 info@enware.com.au



dimensions

BUBBFRWEL-LL

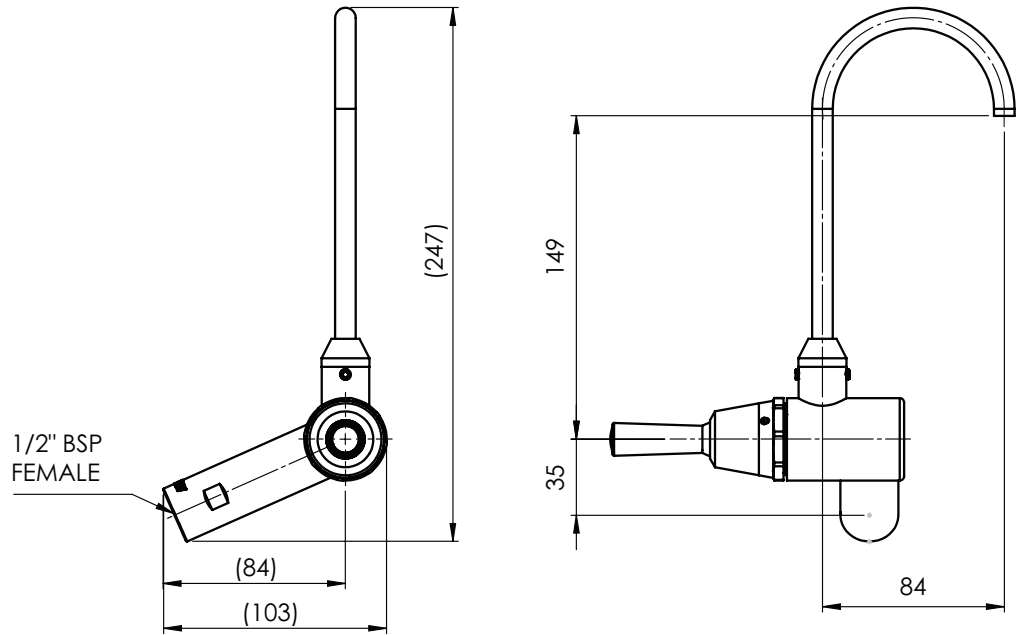

BUBBFRWEL-LR

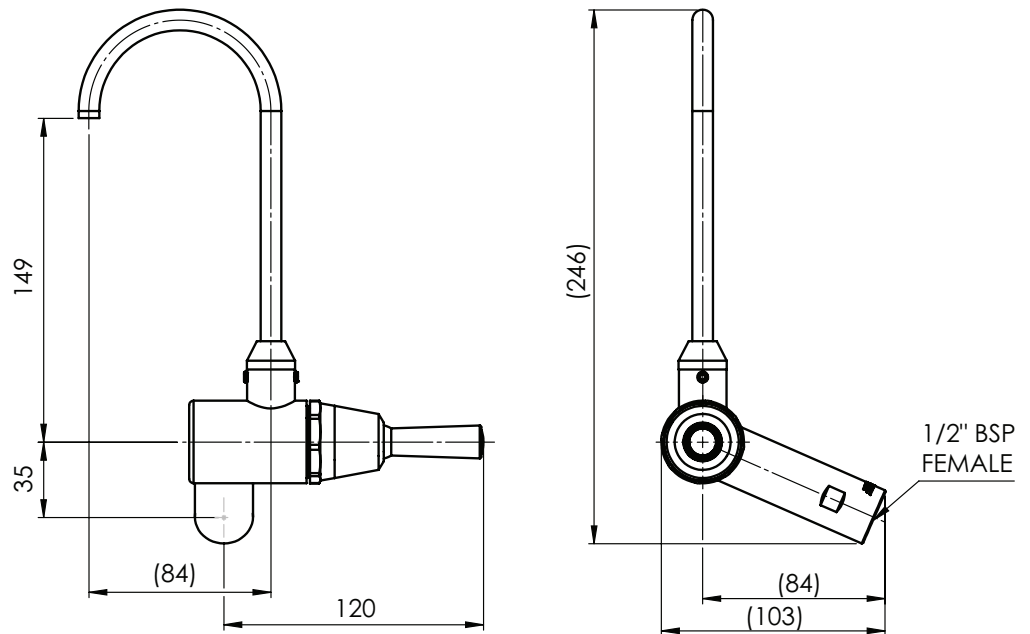

technical data

Inlet Connection	1/2" BSP (15mm)
Operating Working Pressure *	50 - 500 kPa
Flow Rate	5 L/min
Recommended Temperature Range	5 - 30 °C
Operating Temperature Range	0 - 50 °C *

installation compliance

* Enware products are to be installed in accordance with the Plumbing Code of Australia (PCA) and AS/NZS3500. Installations not complying with PCA and AS/NZS 3500 may void the product and performance warranty provisions.

Reference should also be made to the Australasian Health Facility Guidelines (AHFG), ABCB and Local Government regulations when considering the choice of, and the installation of these products.

NOTE: Enware Australia advises:

1. Due to ongoing Research and Development, specifications may change without notice.
2. Component specifications may change on some export models.

All measurements are in millimetres.

installation

BEFORE PROCEEDING WITH INSTALLATION

Ensure all supply lines are flushed thoroughly to remove debris prior to the installation of this product as per AS/NZS 3500.1. Strainers (40 mesh) are recommended if debris is an ongoing problem.

1. Prepare a 1/2" BSP male thread on trough for water inlet, allowing approx. 12mm - 14mm of thread proud from the mounting surface.
2. Apply thread sealant to the 1/2" BSP thread connection, and screw the bottle filler onto the thread. Use a spanner on the flats provided at the base of the body to tighten into position. Do not use the spout or the dome to tighten.
3. Turn water on and check the threaded joint for leaks.
4. Test operation of the bottle filler.

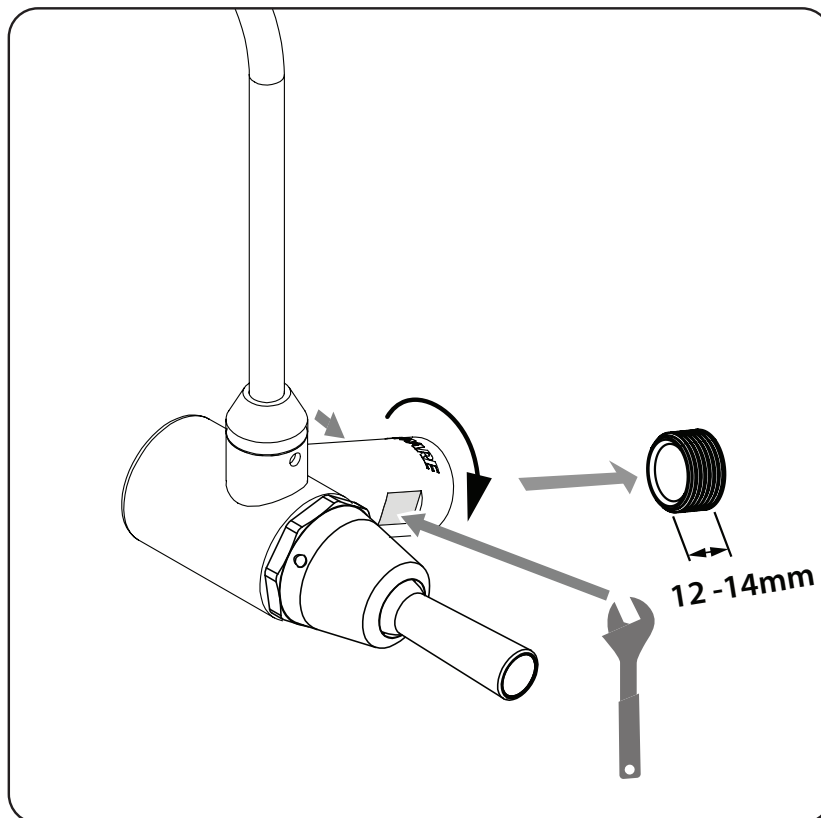

operation

To turn ON, push the lever down.

To turn OFF water flow, let go of the lever.

Water flow stops automatically.

(Lever can be pushed up, down, or sideways.)

Spout can swivel to desired position.

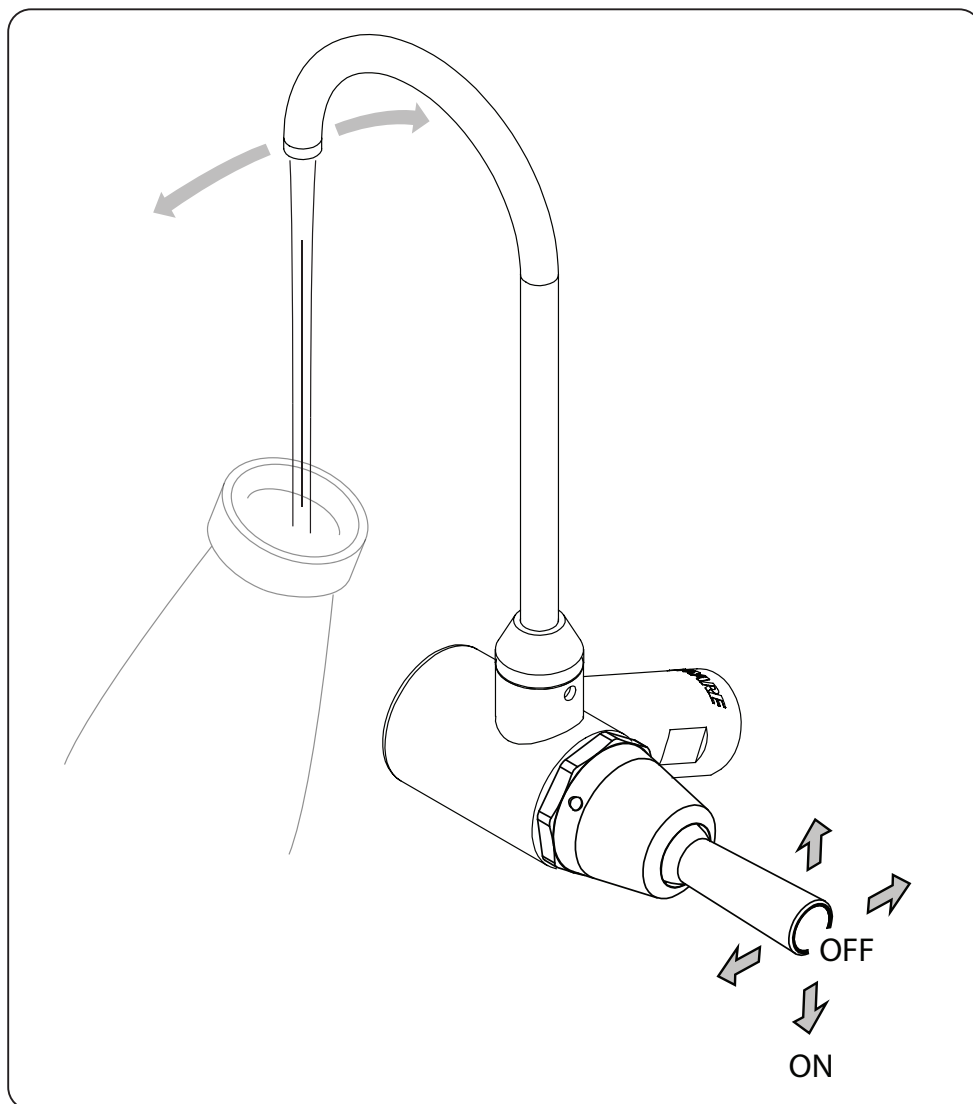

components & spare parts

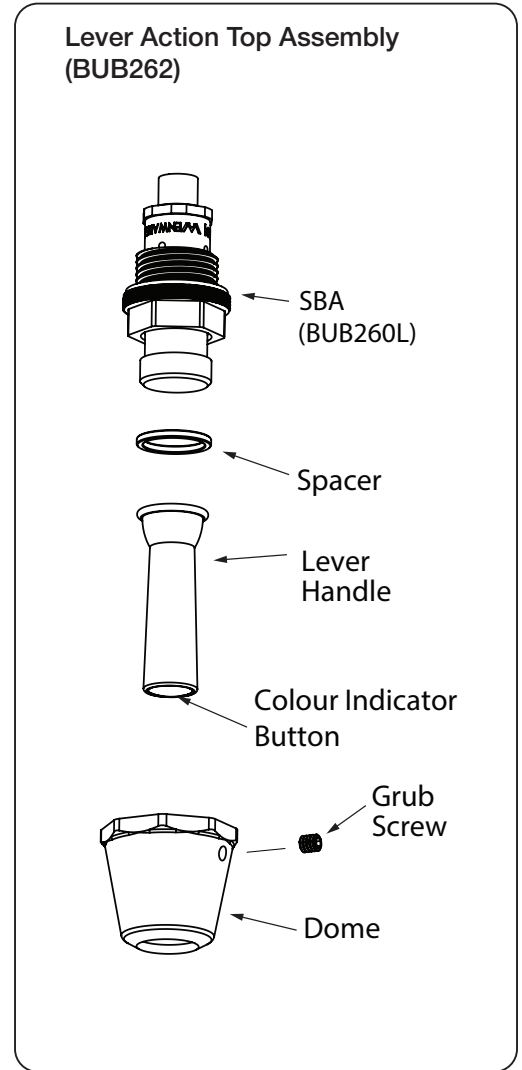
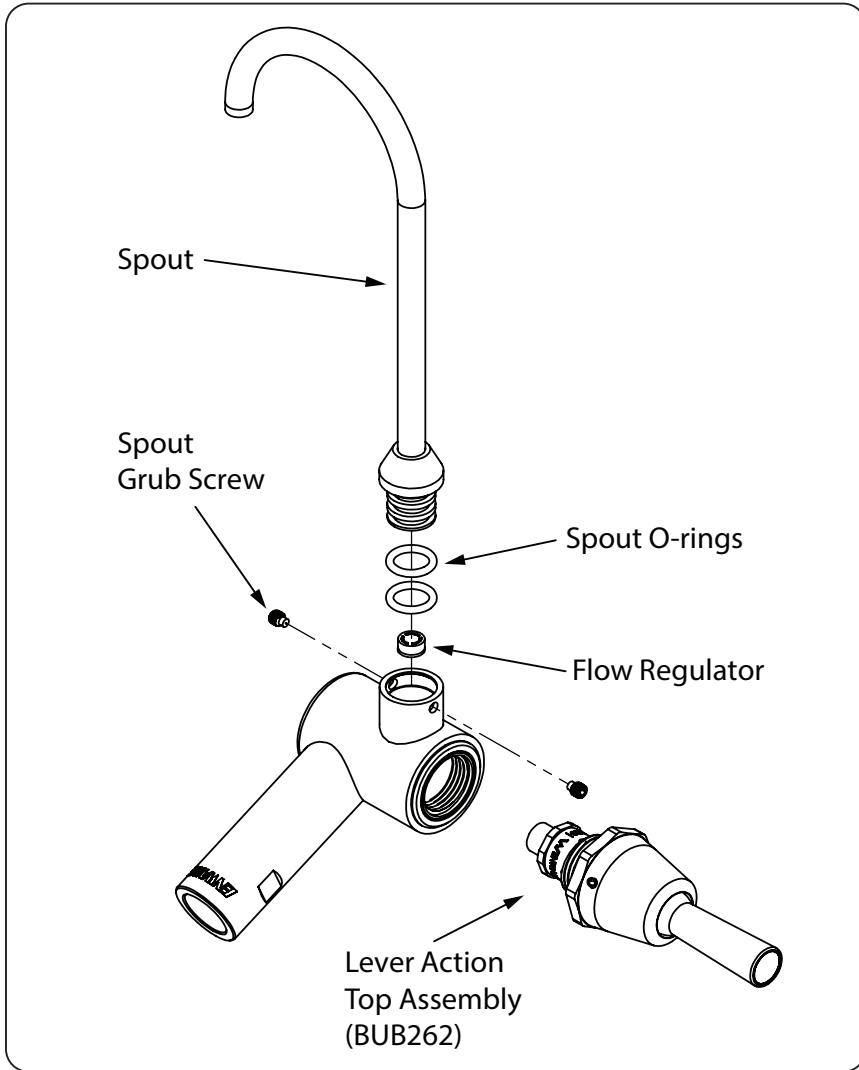

PART	ENWARE SALES CODE
Lever action top assembly	BUB262
Lever action SBA	BUB260L
Spring action SBA service kit Includes 2x piston o-rings, 1x spring, 1x light spring, 1x ball bearing, 1x ball seating washer, 1x seat o-ring, 1x red fibre washer	BUB289
Lever action dome (with grub screw)	BUB221L
Grub screw 10-24 UNC x 3/16 SS	672455

PART	ENWARE SALES CODE
Colour indicator button (specify cold, warm or hot)	MIS595
Spout O-ring (BS112)	670435
Spout grub screw M5 dog point	672453
Flow regulator (5L/min)	671464
Allen key 3/32"	MIS592

service & maintenance

DOMES ADJUSTMENT

Adjust the position of the dome if:

- there is play on the lever handle that needs to be adjusted;
- if the bottle filler is not shutting off completely / water constantly running; or
- if there is no water flow

Adjust the dome by carrying out the following steps:

1. Using a 3/32" or 2.5mm Allen key, undo the grub screw located on the side of the dome cover near the hex.
2. Unscrew the dome from the SBA slowly. The water flow should stop.
3. Now this time, screw the dome into the SBA. Water should begin to flow from the outlet.
4. At this point, unscrew the dome just slightly by approx. 1/4 to 1/2 a turn - the water should stop flowing from the outlet. This is the ideal position of the dome.

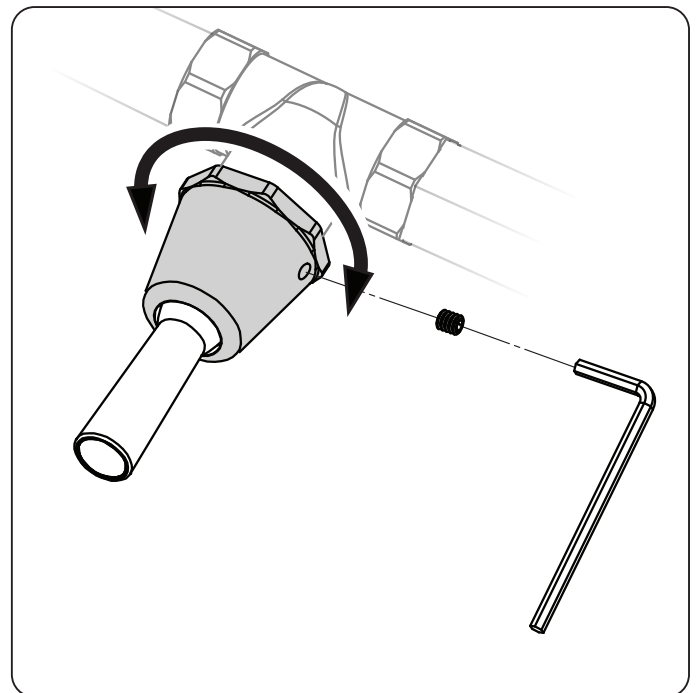

If the dome is screwed in too far, the lever handle will push the SBA piston down and let water through constantly. If the dome is wound too far out, the lever handle will have too much play and will feel loose.

5. Once the correct dome position is achieved, install the grub screw ensuring it is tightened square against one of the SBA flats underneath to maximize vandal resistance.
6. Re-test the tap for correct operation.
7. If problems persist, refer to TROUBLESHOOTING.

SPRING ACTION SBA

It is recommended that the spring action be periodically serviced. As a guide, every 6 months the spindle should be cleaned and re-greased, and the handle insert and other components checked for tightness. The servicing interval will vary depending on the frequency of use of the product, water quality and the general environment.

If the components inside the SBA are worn or damaged, replace the SBA or use the service kit to replace components.

REMOVING THE TOP ASSEMBLY TO ACCESS SBA, CLEANING & REFITTING

1. Using a 3/32" or 2.5mm Allen key undo the grub screw located near the hex of the dome.
2. Unscrew the dome from the SBA.
3. Remove any grease or scale build up in the dome and the top assembly components. Use a diluted solution of CLR for cleaning if necessary.
4. Refitting the top assembly: Grease the inside of the dome around spindle mechanism
5. Fit the dome and handle assembly.
6. Adjust the position of dome. SEE DOME ADJUSTMENT

CLEANING AND LUBRICATING THE SPINDLE

The spring action can be maintained by simply cleaning and lubricating the spindle (piston) using a silicon- based lubricant approved for potable water. This can be done without turning off the water supply.

1. Pull out the piston (the top part) of the SBA and wipe off any excess grease. SEE IMAGE NEXT PAGE
2. Clean the two small o-rings. Replace them if necessary, and re-grease them.
3. Push the piston back into the SBA.

REPLACING THE SBA

1. Shut off water supply and remove the top assembly.
2. Use a suitable spanner (26mm) and unscrew the SBA from the tap body. Make sure the seal o-ring is not left on the seat of the body and the old red fibre washer is also removed.
3. Replace with a new SBA.
4. Turn on water supply.
5. Depress the piston to start water flow. Release the piston to stop the flow and check for

leakage. If a leak is present refer to Troubleshooting to identify cause of leakage and rectify before proceeding.

SERVICING THE SBA WITH SERVICE KIT

1. Pull the piston assembly out from the SBA and remove the 2 piston o-rings.
2. Use a spanner to unscrew bottom inlet port, remove spring and stainless steel ball in the port.
3. Insert a small screw driver in centre hole of the ball seating washer and remove the ball seating washer by levering it out.
4. Clean all brass and chrome components. Remove any debris or scale, especially on the piston, spindle and in the dome. Use a diluted solution of CLR for cleaning if necessary. Check all brass components for wear or damage.
5. Lightly grease the two small piston o-rings with a silicon based, potable water approved grease (e.g. Hydroseal Tap Lubricant or Molykote111) and fit the two o-rings to the piston.
6. Now reassemble the SBA with new components from Service Kit. Place the ball seating washer, ball and spring back in the bottom inlet port, and tighten up the bottom inlet port to the SBA. Refit the seat o-ring and seating washer. Push the piston into the SBA.

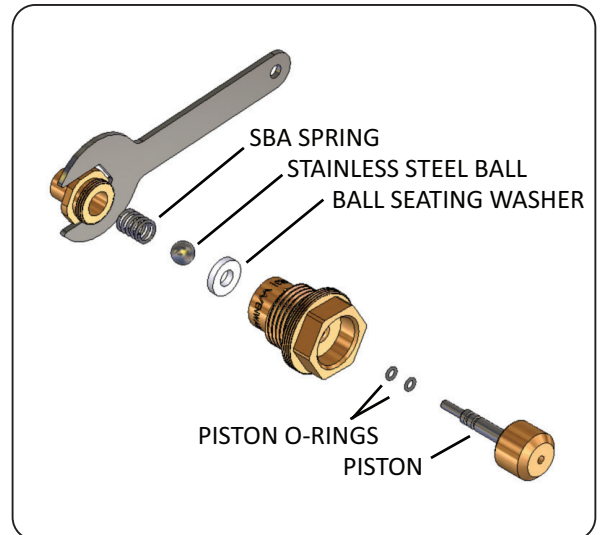

cleaning

Enware product should be cleaned with a soft damp cloth using only mild liquid detergent or soap and water. Do not use cleaning agents containing a corrosive acid, scouring agent or solvent chemicals.

Do not use cream cleaners, as they are abrasive. Epoxy coated surfaces should only be cleaned with a cloth and clear water or mild detergent. Use of unsuitable cleaning agents may damage the surface. Any damage caused in this way will not be covered by warranty.

If re-greasing spindles, always use a silicon-based potable water approved lubricant such as Hydroseal 'O' Ring Lubricant or Molykote 111 silicone based grease.

troubleshooting

PROBLEM	CAUSE	RECTIFICATION
Water runs constantly from outlet	Dome screwed in too far	Adjust dome. See DOME ADJUSTMENT
	Dome incorrectly adjusted	Adjust dome. See DOME ADJUSTMENT
	Debris fouling ball seating washer or stainless steel ball	Dismantle SBA and clean
	SBA ball seating washer is damaged or spring is broken	Replace SBA components using SBA service kit BUB289, or replace SBA
No flow from outlet	Water supply turned off	Turn water on
	Debris fouling inlet or outlet ports of SBA	Remove SBA and remove blockage
	Rubbish/debris fouling outlet	Remove blockage from outlet
	Dome incorrectly adjusted	Adjust dome. See DOME ADJUSTMENT
Handle feels too loose	Dome screwed out too far Dome incorrectly adjusted	Adjust dome. See DOME ADJUSTMENT
Spring action does not move	Piston in SBA is seized	Clean piston and piston o-rings, and re-grease. Use SBA service kit BUB289. (See service and maintenance)
Water discharge from top of dome/ SBA	Piston O-rings are worn	Replace O-rings using SBA service kit BUB289. Re-grease piston (See service and maintenance)

Enware Australia Pty Limited (ACN 003 988 314) (“we” or “us”) warrants that this product (also referred to as “our goods”) will be free from all defects in materials and workmanship for 12 months from the date of purchase. Our liability under this warranty is limited at our option to the repair or replacement of the defective product or part, the cost of repair of the defective product or part or the supply of an equivalent product or part, in each case if we are satisfied the loss or damage was due to a defect in the materials or workmanship of the product or part. All products must be installed in accordance with the manufacturer’s instructions, the PCA, and AS/NZS3500 including any other applicable regulatory requirements.

making a claim

To make a claim under this warranty you must notify us in writing within 7 days of any alleged defect in the product coming to your attention and provide us with proof of your purchase of the product and completed the Online Product Service and Warranty Form available on website www.enware.com.au/product-service-enquiry.

All notifications and accompanying forms must be sent to us marked for the attention of the Enware Australia Pty Limited, 9 Endeavour Road, Caringbah NSW 2229. We can also be contacted by telephone (1300 369 273) or by email (info@enware.com.au).

Your costs in making a claim under this warranty, including all freight, collection and delivery costs, are to be borne and paid by you. We also reserve the right at our cost to inspect any alleged defect in the product wherever it is located or installed or on our premises.

exceptions

This warranty does not apply in respect of any damage or loss due to or arising from:

- a) Failure by you or any other person to follow any instructions for use (including instructions and directions relating to the handling, storage, installation, fitting, connection, adjustment or repair of the product) published or provided by us;
- b) Failure by you or any other person responsible for the fitting, installation or other work on the product to follow or conform to applicable laws, standards and codes (including the AS/NZ 3500 set of Standards, all applicable State and Territory Plumbing Codes, the Plumbing Code of Australia and directions and requirements of local and other statutory authorities); or
- c) Any act or circumstance beyond our control including faulty installation or connection, accident, abnormal use, acts of God, damage to buildings, other structures or infrastructure and loss or damage during product transit or transportation.

other conditions

Except as provided or referred to in this document, we accept no other or further liability for any damages or loss (including indirect, consequential or economic loss) and whether arising in contract, tort or otherwise. Any benefits available to you under this warranty are in addition to any non-excludable rights or remedies you may have under applicable legislation, including as a “consumer” under the Australian Consumer Law. To that extent you need to be aware that: Our goods come with guarantees that cannot be excluded under the Australian Consumer Law. You are entitled to a replacement or refund for a major failure and for compensation for any other reasonably foreseeable loss or damage. You are also entitled to have the goods repaired or replaced if the goods fail to be of acceptable quality and the failure does not amount to a major failure.

ADDRESS: 9 Endeavour Rd Caringbah NSW 2229 Australia

POSTAL ADDRESS: P.O. Box 2545, Taren Point NSW 2229 Australia

PHONE: +61 2 8556 4000

1300 369 273 (AUS) WWW.ENWARE.COM.AU INFO@ENWARE.COM.AU

ABN 23 003 988 314