

Hob Mounted Bottle Filler - Push Button Activation

BUB302B

Refill and Refresh

It goes without saying that water is essential to our health and wellbeing and super important to keep our children well hydrated while at school.

Encouraging good hydration habits means students need to have easy access to drinking water. Enware's range of bottle fillers are an easy way for school children to refill water bottles regularly throughout the day.

FEATURES

- Vandal resistant design: Push button and concealed aerator designed to be removed using a hand tool only
- Valve has been designed for the rigours of daily use
- Robust design - chrome plated brass body
- Easy push button activation
- Self-closing mechanism
- 5 lpm laminar flow

Product Codes

BUB302B Hob Mounted Bottle Filler - Push Button Activation



Technical Information

Inlet Connection	1/2" BSP (15mm)
Operating Working Pressure *	50 - 500 kPa
Flow Rate	5 L/min
Recommended Temperature Range	5 - 30 °C
Operating Temperature Range	0 - 50 °C *
Bench Thickness	50mm Max.

* Enware products are to be installed in accordance with the Plumbing Code of Australia and AS/NZS3500.

Reference should also be made to the Australasian Health facility Guidelines (AHFG), ABCB and Local Government regulations when considering the choice of, and the installation of these products.

NOTE: Enware Australia advises: 1. Due to ongoing Research and Development, specifications may change without notice; 2. Component specifications may change on some export models; 3. Refer to Warranty Statement for warranty details - www.enware.com.au/warranty

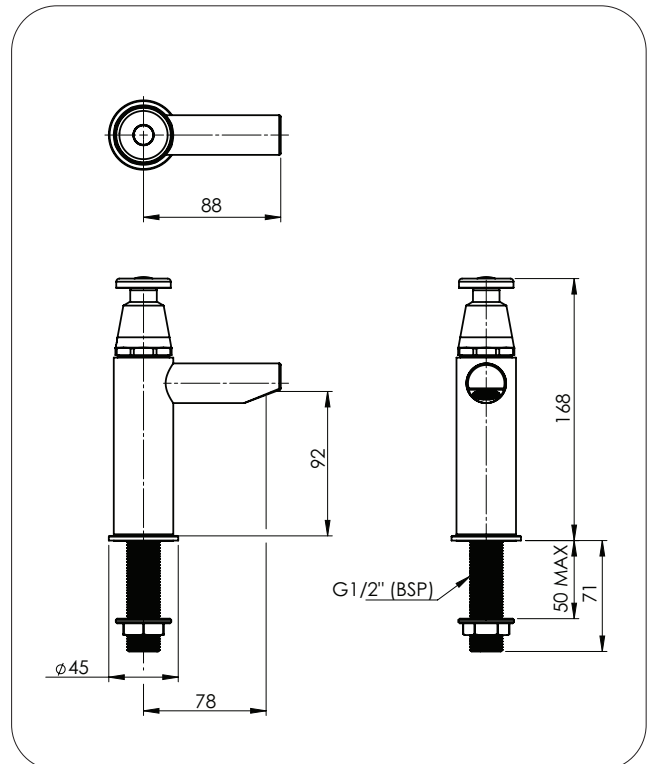
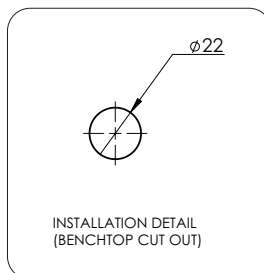

Version: Jan 21

Call 1300 369 273
www.enware.com.au

Enware Australia Pty Limited
9 Endeavour Rd Caringbah NSW 2229 Australia
Ph: 02 8536 4000 info@enware.com.au

