

AQUABLEND SQX THERMOSTATIC MIXERS

Installation Instructions

ATM606 Models



ATM607 Models



ATM6082L



ATM610X / ATM611 Models



I00094_Oct 19

Call 1300 369 273
www.enware.com.au

Enware Australia Pty Limited
9 Endeavour Rd Caringbah NSW 2229 Australia
Ph: +61 2 8556 4000 info@enware.com.au



product descriptions



AQUABLEND SQX THERMOSTATIC BASIN MIXER
ATM606



AQUABLEND SQX THERMOSTATIC BASIN MIXER
with EXTENDED LEVER HANDLE **ATM606D**

AQUABLEND SQX THERMOSTATIC BASIN MIXER
with 100MM LEVER HANDLE **ATM606L**



AQUABLEND SQX THERMOSTATIC SINK MIXER
ATM607



AQUABLEND SQX THERMOSTATIC SINK MIXER
with EXTENDED LEVER HANDLE **ATM607D**

AQUABLEND SQX THERMOSTATIC SINK MIXER
with 100MM LEVER HANDLE **ATM607L**



AQUABLEND SQX THERMOSTATIC RECESSED
WALL SHOWER MIXER with 100mm HANDLE
ATM6082L



AQUABLEND SQX THERMOSTATIC EXPOSED WALL
SURGEON MIXER **ATM611**

AQUABLEND SQX THERMOSTATIC EXPOSED WALL
SURGEON MIXER with REMOVABLE SPOUT
ATM610X

AQUABLEND SQX THERMOSTATIC EXPOSED WALL
SURGEON MIXER with REMOVABLE SPOUT, 215mm
CENTRES

ATM610X-215

contents

Product Descriptions	2	
Technical Data	4	
Installation Compliance	4	
Components & Spare Parts	ATM606	5
	ATM607	6
	ATM6082L	7
	ATM610 / ATM611	8
Installation Instructions	ATM606 ATM607	9
	ATM6082L	10-11
	ATM610X / ATM611	12-13
	Handle Assembly & Positioning	14-15
	Temperature Adjustment	16
	Swivel Spout Assembly	17-18
Maintenance	19	
Commissioning	19	
In Service Tests	20	
Servicing	21-23	
Troubleshooting	24	
Warranty	25	
Commissioning Report	26-27	

technical data

Hot Temperature Supply Range	55°C - 85°C	Operating Thermostatic Temp. Range*	full cold - 45°C
Cold Temperature Supply Range	5°C - 25°C	Factory Set Thermostatic Temp. Range	39°C - 41°C
Adjustable Temperature	35°C - 45°C	Maximum Thermostatic Temperature	45°C
Operating Working Pressure	20 - 500* kPa	Minimum Flow Rate	2 L/minute
Maximum Outlet Pressure*	500 kPa	Maximum Flow Rate	15.5 L/minute
Permitted Supply Pressure Variation^	10%		

^AS3500.4 clause 1.9.4.2 - The dynamic pressure differential between hot and cold supplies when mixed at a thermostatic mixing valve shall not exceed 10%.



installation compliance

*Enware products are to be installed in accordance with the Plumbing Code of Australia (PCA), AS/NZS3500 and the manufacturer's instructions. Installations not complying with PCA, AS/NZS 3500 and the manufacturer's instructions may void the product and performance warranty provisions.

To effectively control microbial hazards during system design, installation, commissioning and maintenance, the requirements outlined in AS/NZS3666 and local legislation shall be adhered to

AQUABLEND SQX THERMOSTATIC MIXERS are **WaterMark approved to AS4032.1** and should be installed using the appropriate Standard, Code of Practice and legislation applicable to each state. Thermostatic mixing valves must be installed by a qualified plumber.

Prior to installation the system must be checked to ensure the system operating conditions fall within the recommended operating range specified in above Technical Data. If the valve is not installed correctly it will not function correctly and may put users in danger and valve warranty may also be void.

To ensure the Thermostatic mixer operates correctly it is necessary that pipework be thoroughly flushed with clean water before installation as per AS/NZS 3500.1. This will remove any physical contaminants from pipework, ensuring trouble-free operation.

Before installation ensure all operating and dimensional specifications are suitable for the intended installation.

If debris is an ongoing problem, the use of strainers (40

mesh) is recommended. A Pressure reduction valve may be required to comply with recommended maximum supply pressure.

THE FOLLOWING CLAUSES MUST BE OBSERVED FOR A COMPLIANT INSTALLATION AND CORRECT OPERATION:

Plumbing Code of Australia: Part B1 Cold Water Services AS/NZS 3500.1-2003 Water Services;

- Section 1.6(a) Facilities for people with Disabilities
- Section 3.3.2 Pressure at outlets (min 50kPa)
- Section 3.3.4 Maximum pressure within buildings (500kPa static)
- Section 3.4 Velocity Requirement (Max 3.0m/s)
- Section 16 Testing and Commissioning; Flushing, Hydrostatic testing, cleaning and disinfection of water services.

Plumbing Code of Australia: Part B2 Heated Water Services AS/NZS 3500.4-2003 Heated Water Services;

- Section 1.9 Water Temperature
 - 1.9.1 Storage Temperature
 - 1.9.2 Sanitary fixtures delivery temperature
 - 1.9.3 Acceptable solutions for control of delivery temperatures
- Section 10 Heated Water Services for People with Disabilities
- Section 11 Testing and Commissioning

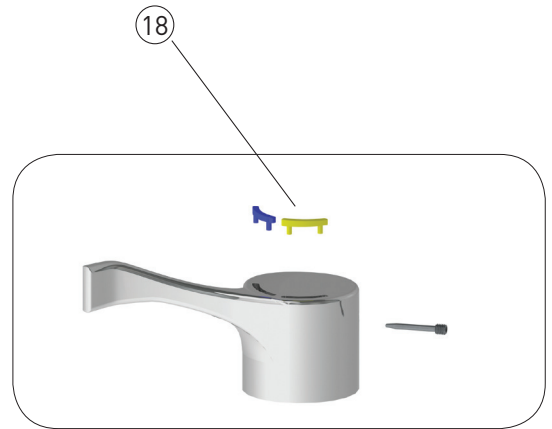
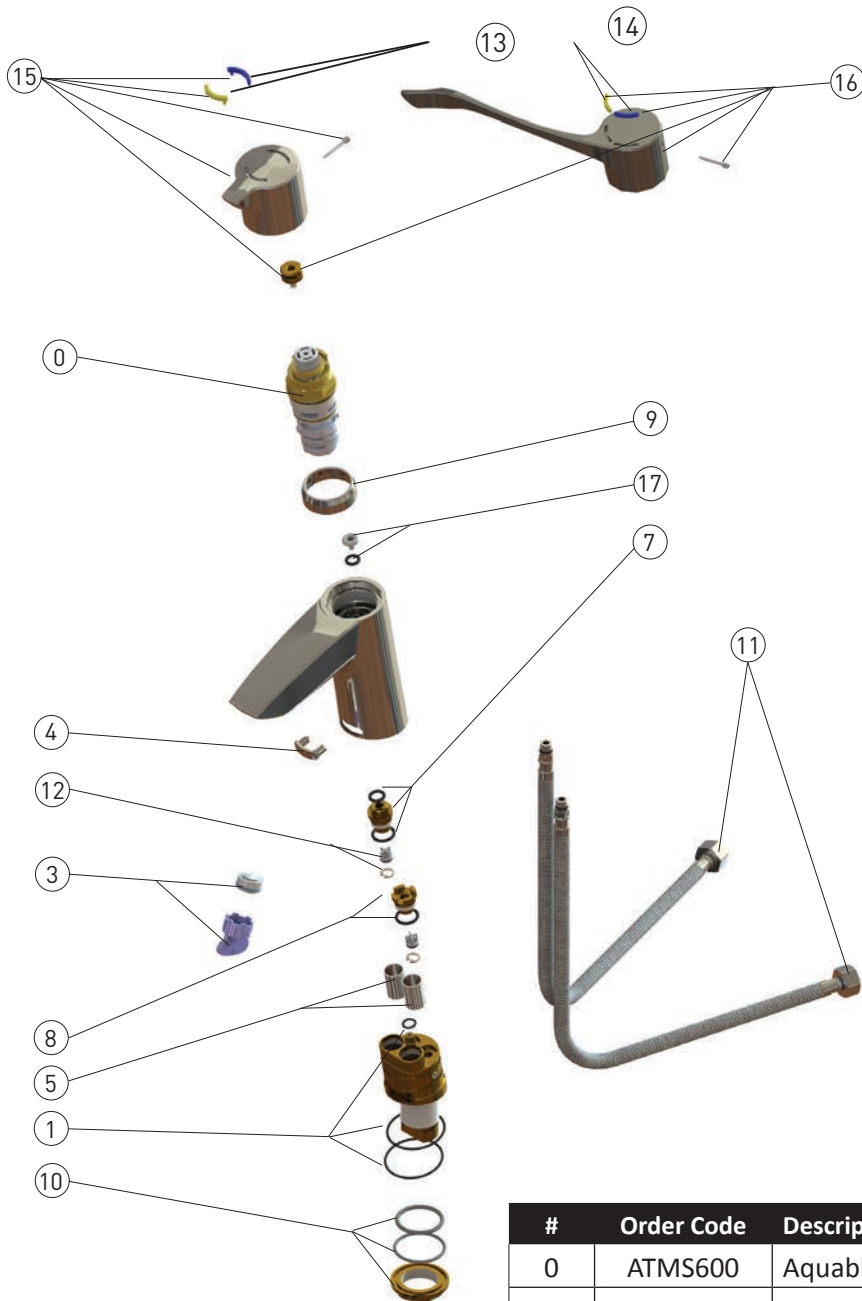

#	Order Code	Description
0	ATMS600	Aquablend SQX Cartridge Replacement
1	ATMS601	O-Ring Kit SQX Basin/Sink Models
3	ATMS603	Aerator and Key SQX 8lpm
4	ATMS604	Cover SQX Isolation Valve
5	ATMS605	Inlet Strainer x2 SQX Basin/Sink Models
7	ATMS607	Connector Inlet SQX Basin/Sink - Hot
8	ATMS608	Connector Inlet SQX Basin/Sink - Cold
9	ATMS609	Dress Ring SQX Basin Model Only
10	ATMS610	Fixing Kit SQX Basin/Sink Models
11	ATMS611	Hose 1/2" BSP x M10 350mm Long H&C
12	ATMS612	SQX Check Valve 10mm x2
13	ATMS613	Indicator Kit - SQX Short Handle
14	ATMS614	Indicator Kit - SQX Extended Handle
15	ATMS615	SQX Handle Complete Assembly - Short Handle
16	ATMS616	SQX Handle Complete Assembly - Extended Handle
17	ATMS617	Fixing Nut Kit - Basin Model
18	ATMS697	SQX Handle Complete Assembly - 100mm Lever Handle

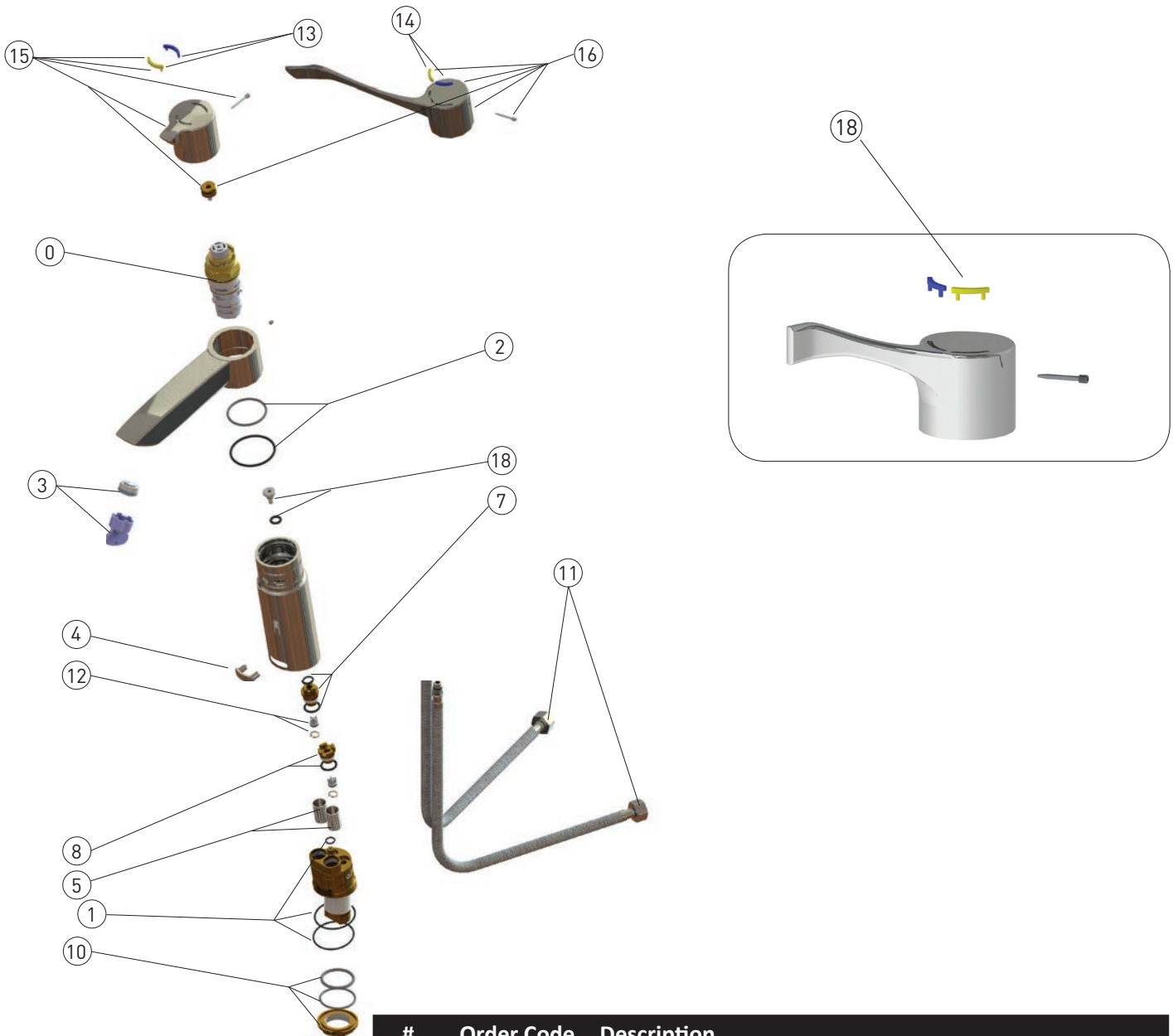

#	Order Code	Description
0	ATMS600	Aquablend SQX Cartridge Replacement
1	ATMS601	O-Ring Kit SQX Basin/Sink Models
3	ATMS603	Aerator and Key SQX 8lpm
4	ATMS604	Cover SQX Isolation Valve
5	ATMS605	Inlet Strainer x2 SQX Basin/Sink Models
7	ATMS607	Connector Inlet SQX Basin/Sink - Hot
8	ATMS608	Connector Inlet SQX Basin/Sink - Cold
10	ATMS610	Fixing Kit SQX Basin/Sink Models
11	ATMS611	Hose 1/2" BSP x M10 350mm Long H&C
12	ATMS612	SQX Check Valve 10mm x2
13	ATMS613	Indicator Kit - SQX Short Handle
14	ATMS614	Indicator Kit - SQX Extended Handle
15	ATMS615	SQX Handle Complete Assembly - Short Handle
16	ATMS616	SQX Handle Complete Assembly - Extended Handle
17	ATMS618	Fixing Nut Kit - Sink Model
18	ATMS697	SQX Handle Complete Assembly - 100mm Lever Handle

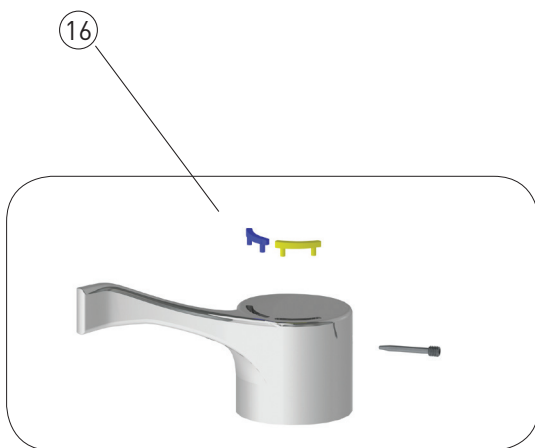
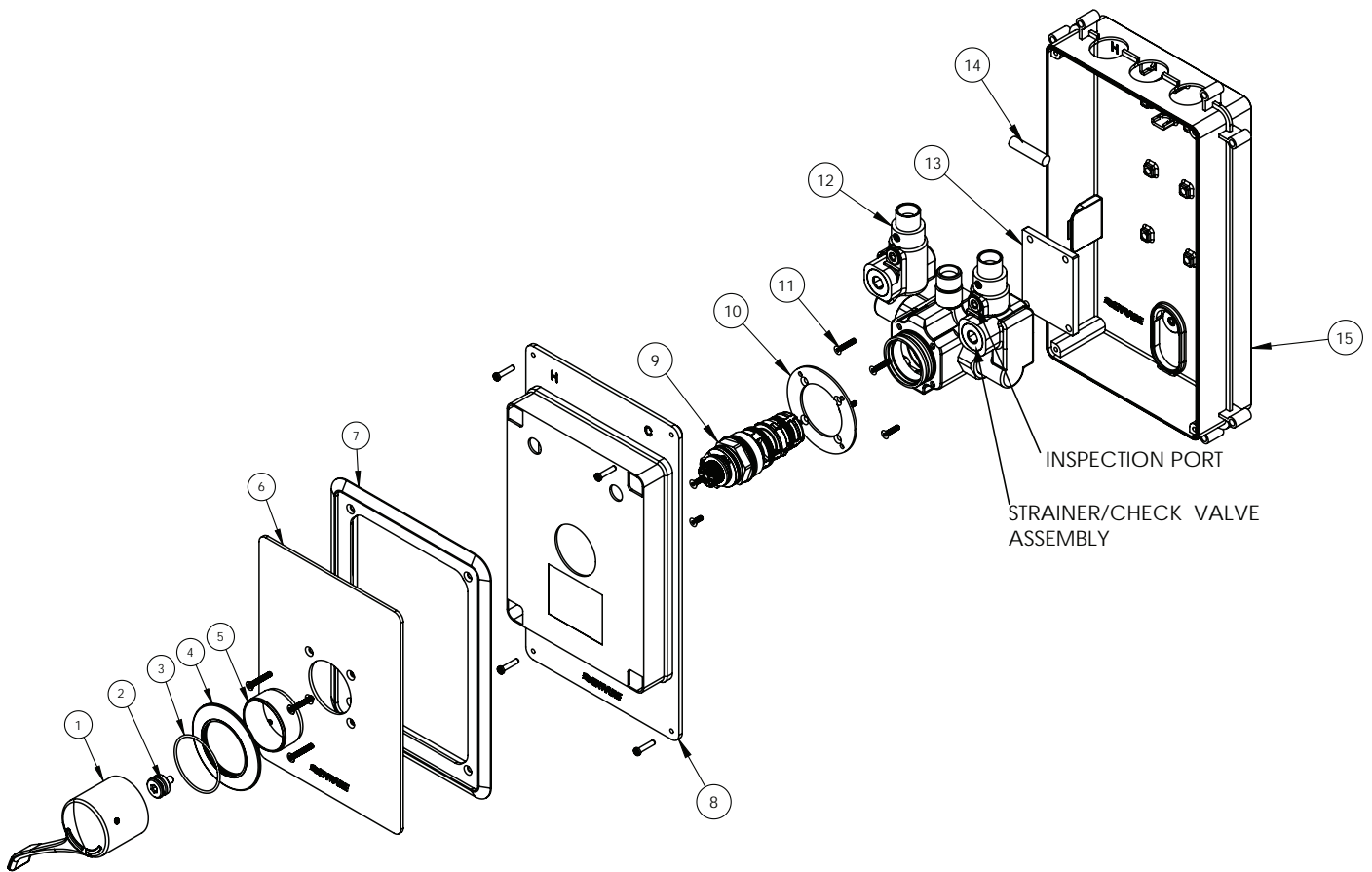

#	Order Code	Description
1	ATMS697	SQX Handle Complete Assembly - 100mm Lever Handle
2		Spline Connector SQX
	ATMS693	Strainer / Check Valve Assembly (1 Pair)
3		O-ring
4		Flange
5		Dress Sleeve
6		Face Plate
7		Bracket
8		In-Wall Box Front Cover
9	ATMS600	Aquablend SQX Cartridge Replacement (5 Year Service)
10		Fixing Base Ring for Front Plate
11		Fixing Screws for Mixer Body
12		Mixer Body
13		Spacer
14		Spirit Level
15		In-Wall Box
16	ATMS613	Indicator Kit

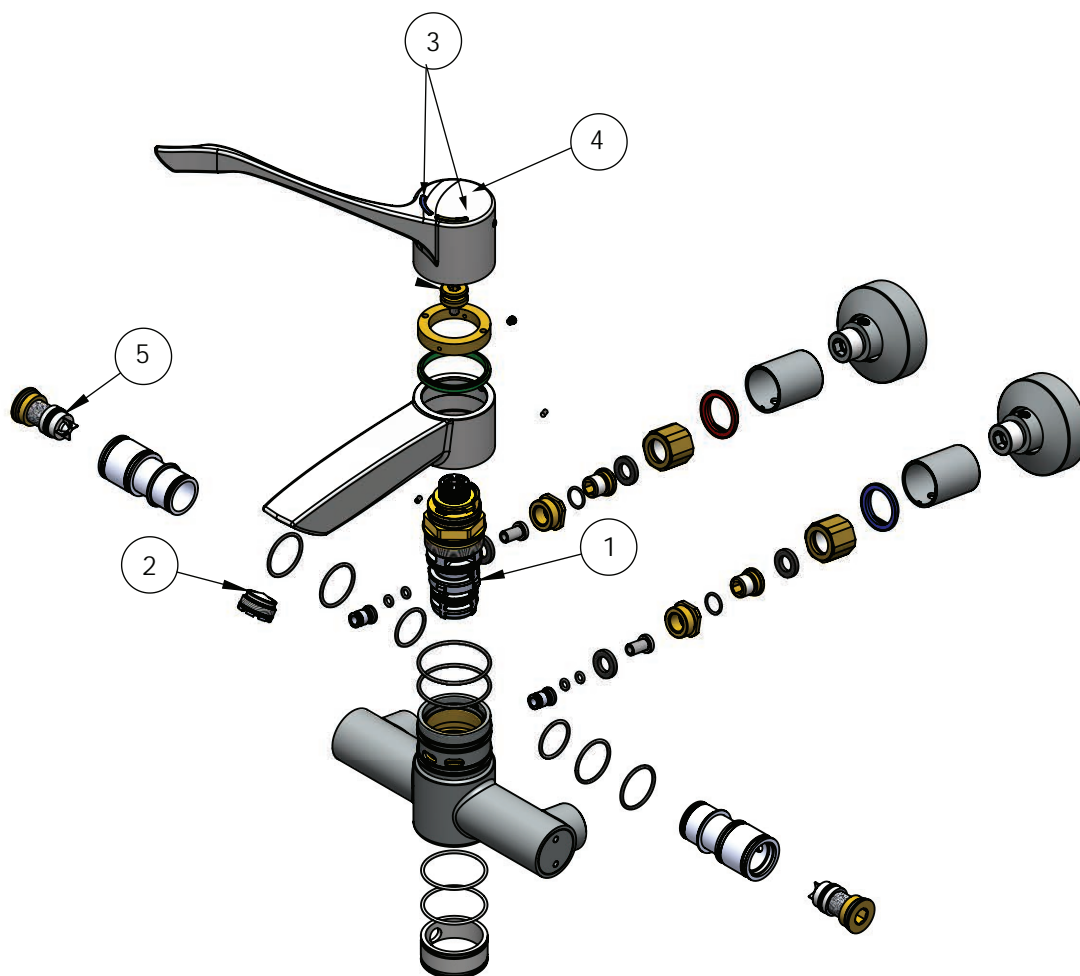

#	Order Code	Description
1	ATMS600	Aquablend SQX Cartridge Replacement
2	ATMS603	Aerator and Key SQX 8lpm
3	ATMS614	Indicator Kit - SQX Extended Handle
4	ATMS616	SQX Handle Complete Assembly Extended Handle
5	ATMS693	Strainer with Check Valve x2 SQX Surgeon Model
6	ATMS696	Wall Union Connector (Each)

1. Isolate water supply before commencing installation.
2. Remove Hob Fixing nut from Basin Mount, feed tap assembly through basin hole. Ensure sealing washer is in position between tap base and basin/sink top. **IMAGE 1**
3. From the underside of the basin/sink, place lower O-ring seal over Basin Mount threaded end and then carefully thread on Hob fixing nut. Use the 38mm socket to tighten and secure tap to the basin/sink. **IMAGE 2**



IMAGE 1



IMAGE 2

Note: Over-tightening Hob Mount fixing nut may cause ceramic basins to crack.

4. Thread each flexi-hose into the base of the Basin hob. Ensure the COLD (Blue) hose is connected to the side marked 'C' or side with a 'Blue' label and the HOT (Red) hose into the side marked 'H' or 'Red' label. **IMAGE 4**

Hand tighten until flexi-hose comes to a firm stop and do not over tighten as hose may kink.



IMAGE 3

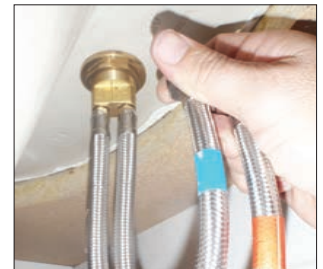

IMAGE 4

5. Connect the SPEX hoses to the water supply outlets making sure that the hot water supply is connected to the hot water hose.

NOTE: It is a requirement of AS/NZS 3500 that the SPEX hoses are connected directly to isolation valves installed at this position.

6. Using a small flat screw driver or Allen Key, ensure both Isolation Valves within the SQX mixer are turned off with their slot in the horizontal position. **IMAGE 5**

Turn the hot and cold water supplies on and check for leaks.

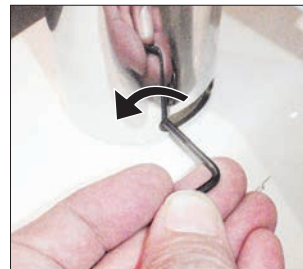

IMAGE 5



IMAGE 6

7. Loosely fit handle over SQX cartridge spline and ensure mixer is in full 'OPEN' position by rotating anti clockwise (see **IMAGE 32** on page 15 for correct handle positions). **IMAGE 6**

Open both hot & cold side isolation valves separately by rotating clockwise 90 degrees, check for leaks. **IMAGE 7**

If leaking refer to Troubleshooting Section on page 25 for possible causes and rectification or contact Enware.



IMAGE 7

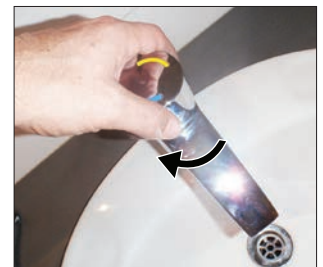

IMAGE 8

8. While the mixer is running, rotate handle in a clockwise motion and test water temperature from the outlet to ensure the water temperature changes with the motion of the handle. **IMAGE 8**
9. Continue to turn handle in clockwise motion to a full CLOSED position and test for leaks while the mixer is closed and pressurised.
10. Commission mixer as per page 19 and complete the commissioning report pages 26-27.

Note: Isolation Valves can be accessed via the front recess on Mixer body. When tested for leaks & calibrated, use SQX Isolation Cover to cover valves from tampering see **IMAGE 55 on page 20.**

1. Determine desired location with relation to the handle height off finished floor. Recommended height from finished floor to cartridge centre for a standard installation is 1100mm.
2. Determine box position in relation to wall depth, considering the thickness of the finished wall. Plastic box may be cut down smaller if required **SEE IMAGE 9**.
3. Mark out fixing point locations while ensuring the box is level. The spirit level inside the box can be seen through the top access hole. The mixer must be installed with the inlets and outlet pointing up, to ensure the front-of-wall components face the correct direction. **SEE IMAGE 10**
4. Secure the Shower Box to the internal cavity within the wall. The Shower Box can be fixed to a masonry wall or nogging within a wall frame, by using the fixing lugs on the side of the box and four suitable screws.

If installing within a frame wall, fit mounting timber in desired location for box support. 13mm plywood fixed between two vertical in-wall studs is recommended **Important: The depth of box from finished wall to the back of the box must be between 77mm – 92mm**

5. Remove and keep the 4 screws located on the outer edge of the in-wall box, remove and keep front box cover at hand.
6. Purge hot and cold supply lines ensuring all debris has been cleared. Then, connect water supply to inlet fittings using 1/2" BSP fittings.

Note: Hot and Cold water connections should use unions or loose-nut connectors to facilitate future servicing or repairs.

Warning: Heat must not be applied to the inlets and outlet of the mixer while connected to the shower body, as this may result in damage to the internal components and void warranty. If hot works are required, disconnect the loose nuts from the body before commencing.

7. Connect mixer outlet to riser leading to shower outlet.
8. Turn ON hot and cold water supplies and check for leaks in the 1/2" threaded joints.

Important: Maximum Static Pressure for testing and commissioning purposes is 1000 kPa

9. Ensure Hot and Cold isolation valves are in the closed position. **SEE IMAGE 10**. Use a 3mm Allen key or flat head screw driver to rotate the isolation valve so that the slot within its head is horizontal (closed position).
10. Place the box front cover back over the mixer and fix it in place using the supplied screws previously removed.
11. The wall is ready to be sheeted. Make sure sheeting is finished hard up against the protruding section of box. *Box cut-out size: 166 mm wide x 222 mm high*

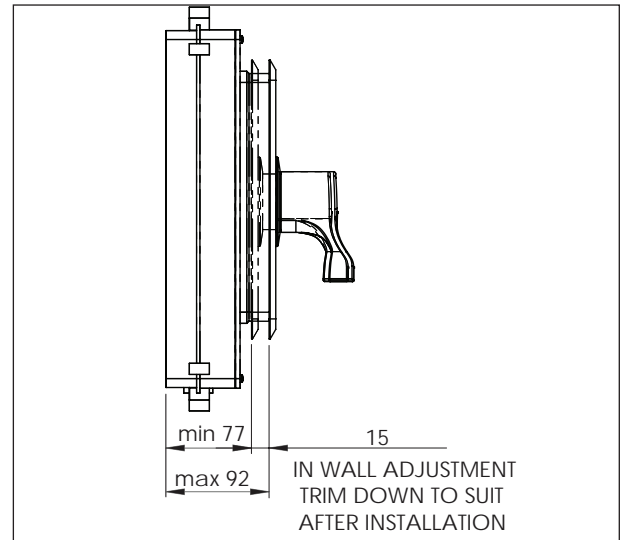

WALL DEPTH: Max. 92mm, Min. 77mm

IMAGE 9

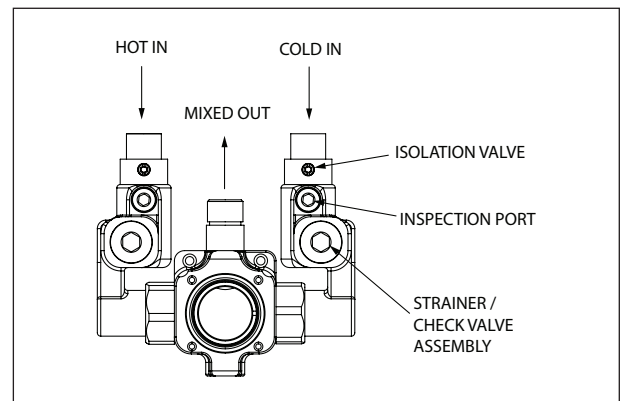

IMAGE 10

AFTER THE WALL IS FINISHED

1. Once the finished wall is complete, the protruding section of the box needs to be trimmed so it finishes flush with the front of the wall face. Discard the cover.
2. Fit the chrome back support bracket.
3. Take the chrome cylindrical dress sleeve and push it onto the mixer body ensuring the O-rings on the mixer body are greased.
4. Fit the face plate over the chrome sleeve and secure using 4 x M4 screws supplied.
5. Take the chrome flange, lightly grease the O-ring and push over the chrome dress sleeve until it is hard up against the face plate.
6. Screw the brass spline connector into the top of the mixer cartridge
7. Fit the handle over the spline connector.
8. Insert the M5 fixing pin into the side of the handle and tighten making sure you are left with no movement in the handle. If the pin does not screw in all the way or the handle has movement, remove the handle and adjust the spline connector, then re-fit the M5 fixing pin.
9. The valve can now be commissioned.
Commission the valve as per the instructions on page 19, and complete commissioning report on page 26.

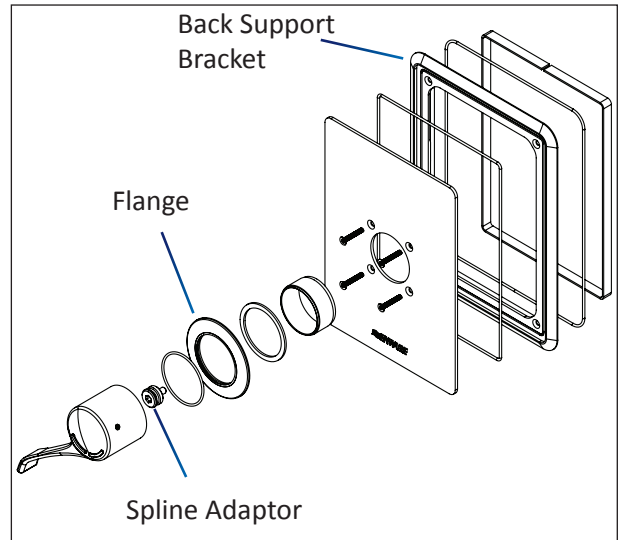

IMAGE 11

Extra Components Supplied:

- 1x Large Plug for Body (in place of SQX Thermostatic Cartridge during servicing)
- 2x Small Plugs for inlets (in place check valve strainer assemblies during servicing)



TOOLS REQUIRED: Thread sealing tape or equivalent, 3/8" Allen key, spanner, flat head screw driver, 3mm Allen key

SETTING OUT/ROUGH IN

1. Determine set out height from finished floor level. Recommended height for water points is 1120mm when coupled with basin at a height of 865mm.

* Recommended spout height (point of water discharge) for Type A and B Clinical Hand Washing Bay is 1120mm off finished floor level when combined with basin at a height of 865mm, according to Australasian Health Facility Guidelines.

2. Secure the hot and cold 15mm (1/2" BSP) male threaded inlet points with the centres 150mm apart (215mm for -215 model, 80 - 140mm for -ADJ models), and level, making sure enough thread is left to protrude a minimum of 16mm past finished wall. (HOT on the left, COLD on the right when facing the wall, as per standard set out) SEE **IMAGE 12**

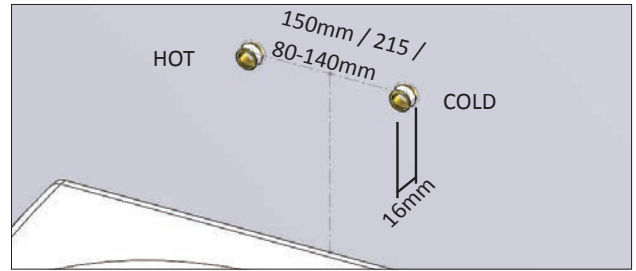

IMAGE 12

FIT OFF

1. When finished wall is complete make sure thread is at a length of 16mm. Cut if needed.
2. Flush the hot and cold supply lines. Purge hot and cold supply lines to make sure all debris has been cleared.
3. Apply thread tape or an equivalent approved thread sealing product to exposed 15mm water points. Seal any gaps between thread and wall with silicone.
4. Place chrome dress flange over supply inlets making sure base o-ring is contained in its correct position within the dress flange. See **IMAGE 13** and **14**
5. Install isolation valve connector onto 1/2" BSP thread of water supply inlets, and tighten using a 3/8" Allen key until flange is held **FIRMLY** against wall. See **IMAGE 15**
6. Close the isolating ball valves using a 3mm Allen key or a flathead screw driver. The line of the slot on the control should be positioned cross-wise to the direction of water flow. See **IMAGE 16** and **17**
7. The hot and cold water supplies can now be turned on for testing. Check for leaks.
8. Before connecting the main tap frame, flush the lines again to ensure all debris has been cleared.
9. Place the chrome sleeves over each of the isolation connectors and push them back until they come to a stop and they are positioned within the wall flange. Note the orientation of the sleeve – the access hole should be closer to the user, so that when pushed all the way back, the hole can line up with the isolation valve. The sleeve is free to spin right around. See **IMAGE 18** and **19**
10. On the main mixer body, place rubber washers inside fixing nuts as shown (if not installed already) **IMAGE 20**.

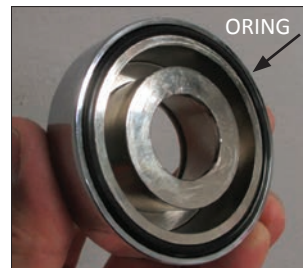

IMAGE 13



IMAGE 14



IMAGE 15



IMAGE 16



IMAGE 17

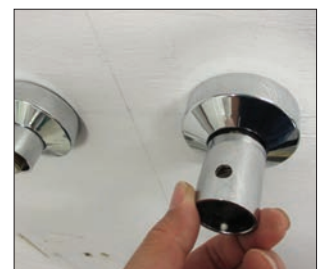

IMAGE 18



IMAGE 19

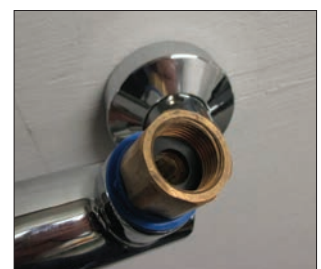

IMAGE 20

13. Take the main mixer body and screw the loose nut connectors to each isolation valve, making sure to tighten hot and cold sides simultaneously. Use a spanner to tighten, but hold against yourself by inserting a 3mm Allen key or flat head screw driver into the isolation valve control. See **IMAGE 21** and **22**. **Do not over-tighten.**



IMAGE 21

14. Place the lever handle on the cartridge spline and turn anti clockwise until it stops - the valve is now in its open position. See **IMAGE 23**



IMAGE 22



IMAGE 23

15. Turn on water supply, by slowly turning the hot and cold isolation valves to on position (valve slot in line with the flow of water) using a 3mm Allen key or a flat head screw driver. Once water flow from the outlet is observed, turn off the tap by turning the lever handle in the clockwise direction until the flow of water stops. Check for leaks. See **IMAGE 24** and **25**



IMAGE 24



IMAGE 25

16. Pull the chrome sleeves over the isolation valves so that they come into contact with the colour temperature indicator rings. To do this, rotate the sleeve so that the key slot on the sleeve lines up with that on the colour indicator. When the key slot clicks into place there should be no gap between the sleeve and the indicator, and the access hole faces down. See **IMAGE 26** and **27**

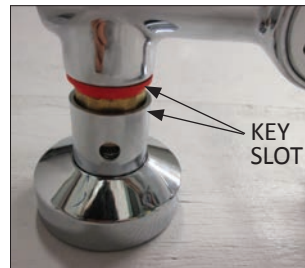

IMAGE 26



IMAGE 27

17. The SQX Thermostatic mixer is now ready for commissioning. Follow the testing and commissioning procedure on page 19.

handle assembly & positioning

The short Lever handle or extended lever handle will be found packed in a separate box with the overall product package, with all necessary assembly tools for each model.

1. Take the Spline Connector out of the plastic bag found within the handle box and screw it onto the SQX cartridge spline until it comes to a firm stop.
2. Loosely place the handle over the SQX cartridge spline and rotate handle in a clockwise motion to fully close the mixer and determine the 'OFF' position. See **next page** for correct handle positions
3. Carefully lift the handle off the spline in its 'OFF' position and align the short handle lever to the front centre location, or for the extended lever, align handle so that the 2 temperature colour indicators are facing symmetrical to the center of the spout. **IMAGES 28 and 29**
4. Take the Handle Locking Pin (found within the clear plastic bag within the handle box), and insert into the back of the handle to secure it to the mixer. Use allen key to tighten Handle locking pin. **IMAGES 30 & 31**

If handle is loose or rocks after this process, remove handle and repeat steps 1-4 above again after you have wound the up Spline connector enough so it provides a tight fit with the Handle Locking pin.

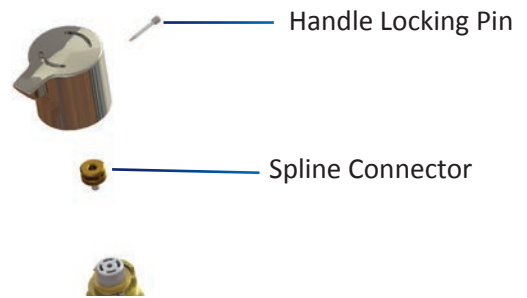

IMAGE 28

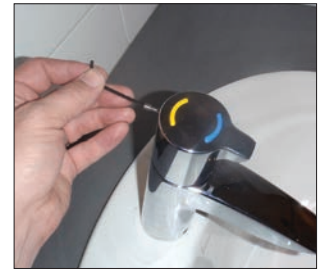

IMAGE 29



IMAGE 30



IMAGE 31

HANDLE POSITIONS

CLOSED (OFF) LIMIT Limiting ring to be installed on cartridge during assembly, after closing the spindle to 2.0Nm. **Not intended to be removed or adjusted once factory set.**

UPPER TEMPERATURE LIMIT Limiting ring to be installed on cartridge during assembly to limit allowable upper temperature to 45°C - as per AS 3500.4.

RANGE OF MOVEMENT The spindle rotates from CLOSED to the Factory Set temperature (39° - 41°C) through an angle of approx 120 - 160 degrees.

INSTALLATION TORQUE Cartridge must be assembled into tapware using suitable tooling that applies a torque not exceeding 10Nm to the hexagonal flats on the brass cap **ONLY**.

Anti-clockwise rotation of spindle from closed position - adjustment sequence. (ATM606, ATM6082L, ATM606D)

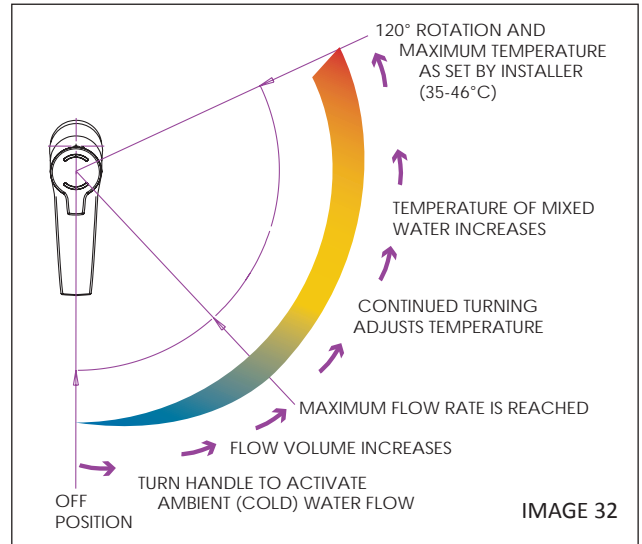

IMAGE 32

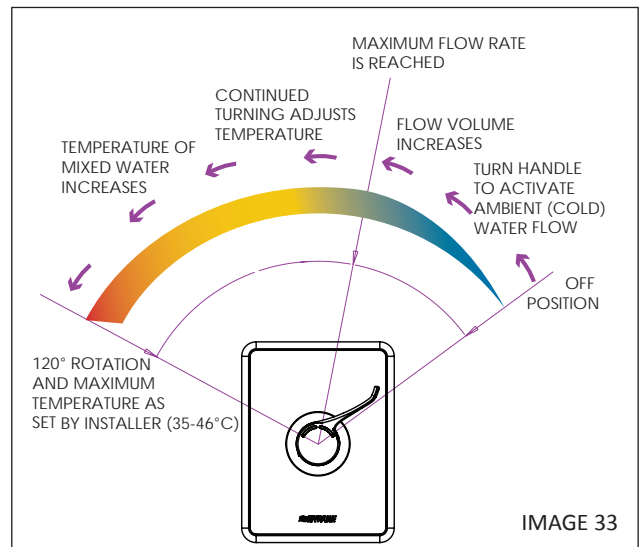

IMAGE 33

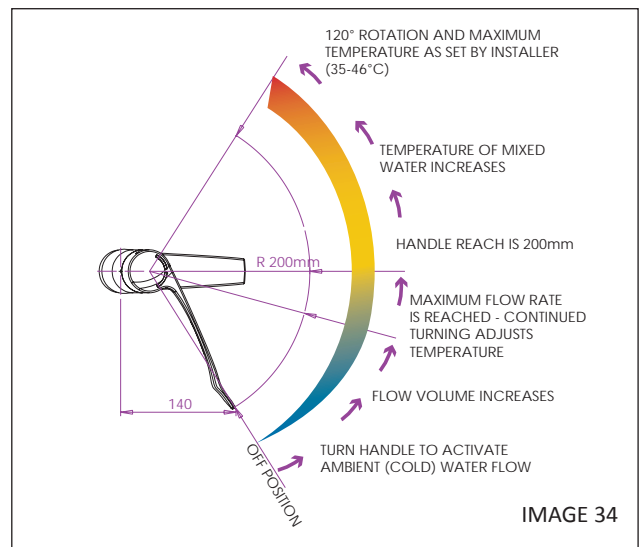

IMAGE 34

temperature adjustment

The ENWARE AQUABLEND SQX Thermostatic Mixers are supplied factory set at a maximum of 41°C +/- 2°C. To alter this temperature adopt the following procedure:

Note: Changing the maximum set temperature will change the amount of rotation of the handle. Increasing the temperature will mean extra rotation, while decreasing the temperature will result in less rotation.

- 1 Ensure the mixer is in the 'OFF' position (refer to **IMAGE 32-34** on page 15). Using a 3mm Allen Key, remove the Handle locking pin and lift the handle vertically off the mixer Cartridge (refer to **IMAGES 35 and 36**).
- 2 With the top of the mixer and cartridge now exposed, remove the upper temperature ring away from the cartridge spline **IMAGE 37** - take care not to remove the lower temperature ring. Loosely re-fit the handle in this 'OFF' position **IMAGE 38**
- 3 Turn the tap on and check the temperature of the water with a hand held digital thermometer. With the thermometer gauge held within the flow stream, continue to move the handle until the desired (Maximum) temperature is achieved.
- 4 Once desired temperature is achieved, remove handle without changing spindle position. Re-fit the upper Temperature cam so the lug can form a stop against the brass shoulder on the cartridge - **IMAGE 39**.
- 5 Loosely re-fit handle and turn to 'OFF' position. Re-fit handle in its correct 'off' position orientation as seen in **IMAGE 20** on page 12.
- 6 Secure Handle again using the handle locking pin and 3mm Allen Key - **IMAGE 40**



IMAGE 35



IMAGE 36



IMAGE 37

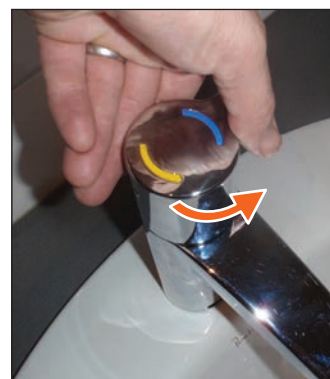

IMAGE 38



IMAGE 39



IMAGE 40

swivel spout assembly notes

LOCKING THE SPOUT IN A FIXED POSITION

The ATM607, ATM610X and ATM611 models come assembled with the Spout in a Swivel orientation where it can be rotated 120 degrees over the basin.

To fix the spout in the straight position:

1. Rotate the spout so it is positioned straight out over the basin. **IMAGE 41** and **42**
2. Tighten the M5 grub screw located on the back of the Swivel spout so it can engage within the locator groove on body. Wind in the grub screw until it comes to a light stop and the head of the grub screw is close to being flush with the surface of the swivel spout. **IMAGE 43**

Note: the spout might be required to be rotated a little while winding in the grub screw to find the correct central location groove.

CAREFUL: Do not over tighten grub screw as it can cause the spout to leak.

3. Use the 1.5mm Allen key to loosen the 2x M3 grub screws located on the spout locking nut. **IMAGE 44**
4. Using the SQX prong tool tighten the Spout locking nut to further secure the swivel spout. **IMAGE 45**
5. Use the 1.5mm Allen key to again tighten both M3 grub screws and test the spout is centrally located and secure. **IMAGE 46**
6. Test operation and check for leaks. If leaks occur around the spout, loosen off M5 grub screw slightly.



IMAGE 41



IMAGE 42



IMAGE 43

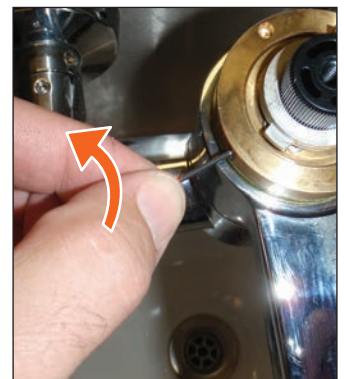

IMAGE 43



IMAGE 45

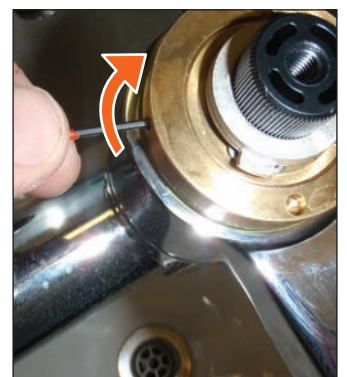

IMAGE 46

CHANGING THE SEALING ORINGS & SWIVEL BUSHES

The Swivel spout orings and swivel bushes can be checked/replaced without isolating the hot and cold water supplies. Ensure the mixer is turned off (**see IMAGE 34 on page 15**).

1. With the handle fully rotated to the clockwise direction, remove handle by unscrewing the locking pin and carefully lifting without rotating the mixer's spindle spline. Once the handle is removed, leave to one side and keep at hand.
2. Use the 1.5mm Allen key and loosen the 2 x M3 grub screws located on the Spout Locking nut. **IMAGE 47**
3. Unwind the Spout locking nut and remove from Cartridge. **IMAGE 48**
4. Remove the M5 grub screw located on the back of the Swivel spout and lift spout up and off mixer body. **IMAGE 49**
5. Inspect Orings and bushes for debris/damage. To remove, carefully slide bush up off the mixer body. **IMAGE 50**
6. Remove both orings from the mixer body and slide off the lower bush. **IMAGE 51**
7. Re-install a new Swivel Bush first and carefully slide it over the mixer body until it comes to rest at the base of the swivel spout mounting area. **IMAGE 52 and 53**
8. Re-install 2 x new orings and the upper bush. Ensure the upper bush comes to rest on the top oring and sit below the swivel spout rotation groove. **IMAGE 54**
9. Grease orings and swivel bushes. Reinstall swivel spout by carefully pushing it firmly over the mixer body.
10. Thread on the Swivel spout locking nut until it comes to rest against the spout and secure in position by tightening the 2 x M3 grub screws.
11. Assemble the handle and test operation for leaks.



IMAGE 47



IMAGE 48



IMAGE 49



IMAGE 50



IMAGE 51



IMAGE 52



IMAGE 53



IMAGE 54

maintenance

The ENWARE AQUABLEND SQX Thermostatic Mixing Valve will only require minimal preventative maintenance work to ensure it operates at its optimum level of performance. The valve should be commissioned and serviced annually, unless the installed conditions dictate more frequent servicing is necessary.

ANNUAL MAINTENANCE PROCEDURE

Every 12 months the ENWARE AQUABLEND SQX thermostatic Mixer should be inspected and tested. The valve should be given a light wipe down of the external surface. The valve and surrounding area should be inspected for leaks or water damage and appropriate action taken if required.

Ensure a clean dry work area is available. Firstly isolate the hot and cold supplies to the AQUABLEND SQX THERMOSTATIC mixing valve by closing the inlet ball valves found at the base of the mixer. During the annual service the SQX Check valve/mesh strainer assemblies need to be removed and cleaned, as directed in Servicing the Mixer Steps 1-3 below.

A thermal shut down test is performed and the temperature is reset as required. If the valve fails to shut down or fails to maintain its set temperature then refer to Troubleshooting section on page 24.

FIVE YEAR MAINTENANCE PROCEDURE

Every five years the ENWARE AQUABLEND SQX thermostatic Mixer needs to have a full service carried out. This service consists of the same procedure as the 'Annual maintenance procedure', and in addition the AQUABLEND SQX THERMOSTATIC mixer Cartridge must be replaced, as directed in the section below - **Servicing the Mixer**.

After replacing the thermostatic mixer Cartridge, a thermal shut down test is performed and the temperature re set as required. If the valve fails to shut down or fails to maintain its set temperature then refer to Troubleshooting section on page 24.

Once the 5 yearly maintenance procedure is complete, the ENWARE AQUABLEND SQX thermostatic Mixer should then be commissioned as per instructions below.

commissioning & in-service tests

Since the installed supply conditions are likely to be different from those applied in the laboratory tests, a simple test should be carry out on each mixer at commissioning to provide a performance reference point for future in-service tests. Check the following in all cases to ensure the correct performance of the thermostatic mixer:

- the designation of the thermostatic tap matches the intended application.
- the supply pressures and temperatures are within the range of operating pressures and temperatures for the designation of the valve.
- the supply temperatures are within the range permitted for the tap and by guidance information on the prevention of Legionella etc.

It is important to record the testing done during the commissioning and also to record the temperature of the hot and cold water supplies and the temperature of the mixed water at the maximum setting.

Upon completion of the installation, the valve should be tested and commissioned as per the procedure outlined below or as specified by the local authority. The entire procedure should be read through thoroughly prior to the commissioning of the valve. A calibrated digital thermometer having rapid response time with maximum temperature hold will be required to check and set the outlet mixed temperature of the mixer.

To test the temperature, open the valve and allow mixed heated water to flow for at least 60 seconds to stabilise temperature before taking a reading at outlet with a digital thermometer. The flow rate should be at least 2L/min.

The temperature should be taken close to the mixer's outlet and if the outlet temperature requires adjustment then follow the Temperature Adjustment steps outlined on page 16.

SHUT DOWN TEST

Once the correct outlet temperature has been achieved, the valve's internal mechanism should be exercised at least 3 times by alternately shutting off the hot and cold supplies while the mixer is set in the full warm position, do this at the outlet using the mixer's separate Hot and Cold isolation Valves. This will cause the piston inside the cartridge to travel its full stroke and ensure that it is moving freely so the valve can operate correctly.

TEST 1

1. Open mixer to the full warm position and with both supplies turned fully on and the system's temperatures, allow the mixed water temperature to stabilise and note the outlet temperature.
2. While holding a digital thermometer in the outlet water flow, quickly isolate the cold water supply to the valve. The outlet flow should quickly cease flowing. As a rule of thumb the flow should be less than 0.1L/min following the isolation.

The temperature should not exceed that allowed by the applicable standard or code of practice for each state.

3. Restore the cold water supply to the valve. After the mixed water temperature has stabilised note the outlet temperature ensuring the outlet temperature has re-established.

TEST 2

1. Repeat the above test, except this time quickly isolate the hot water supply to the valve. The outlet flow should quickly slow to a trickle. As a rule of thumb the trickle should typically be less than 0.4L/min@500kPa down to less than 0.1L/min@100kPa following the isolation.
2. Restore the hot water supply to the valve and measure and record the outlet temperature after the mixed water temperature has stabilised ensuring the outlet temperature has re-established.

Ensure that all details of the Commissioning Report (Page 26) are completed and signed by the relevant signatories, and a copy is kept with the installer and owner of the premises.

The valve is now commissioned and it can be used within the technical limits of operation.

IN-SERVICE TESTING

Enware Australia recommends that Thermostatic Mixing Valves have monthly temperature checks and adjustments as needed during the life of the valves.

The purpose of the in-service tests is to regularly monitor and record the performance of the thermostatic taps. Deterioration in performance can indicate the need for service work on the valve and/or the water supplies.

TESTING PROCEDURE:

Using the same measuring equipment or equipment to the same specification as used in the commissioning of the valve, carry out the following sequence:

1. Record the temperature of the mixed water outlet.
2. Conduct Shut Down Test 1 - Isolate the cold water supply to the tap to witness the flow slow to a slight drip.
3. Conduct Shut Down Test 2 - Isolate the hot water supply to the tap to witness the flow slow to slight drip.

If the mixed water temperature has changed +/- 2°C from the previous test results, then this could indicate the need for the tap to be serviced.

ATM606/607 ISOLATION COVER FITTING

Once commissioning of mixer is complete, insert the Chromed plastic isolation cover by firmly pressing it within the Isolation Access Cavity within the Basin Body to ensure isolation valves are not tampered with after commissioning -

IMAGE 55



IMAGE 55

servicing the mixer

Prior to servicing the mixer, turn off both hot and cold water supply via Isolation valve found at the base of the mixer.

REMOVING SQX THERMOSTATIC CARTRIDGE

ALL MODELS

Only remove cartridge to replace, or to access strainer/ check valve components for ATM606 and ATM607 models.

Do not disassemble cartridge.

1. Ensure both the Hot and Cold water supplies have been isolated by turning both Isolation valves 90 degrees into the 'OFF' position. SEE **IMAGES 56 - 57**.
2. Open the mixer to ensure water supplies have been isolated correctly and no water flows from the outlet prior to servicing mixer.
3. Remove handle by unscrewing the Allen key locking pin on the side of the handle. Once the locking pin is removed, carefully lift the handle straight up out of position off the cartridge spline.
4. Using the supplied cartridge socket on the brass headwork, turn the cartridge counter-clockwise until it reaches the end of its threads and then pull it out of the mixer body. **IMAGE 58 & 59**

IMPORTANT: DO NOT TAKE CARTRIDGE APART



ATM606/607 ISOLATION VALVE IMAGE 56

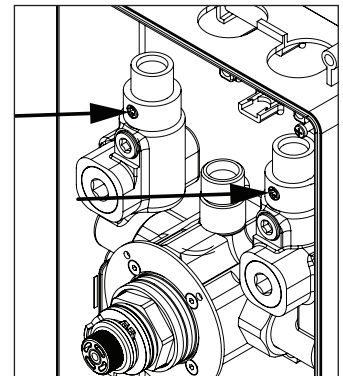

ATM6082L ISOLATION VALVE IMAGE 57



IMAGE 58



IMAGE 59

REMOVING MIXER BODY FROM BASIN HOB

ATM606/607 MODELS

1. Using a small Allen key or screw driver, carefully prise out the plastic chromed isolation cover by levering the end of the Allen key within the small cut-outs found on each side of the cover. Be careful not to damage the chrome surface on the mixer body. **IMAGE 55 page 20**
2. Ensure both the Hot and Cold water supplies have been isolated by turning both Isolation valves 90 degrees into their 'OFF' position - refer to **IMAGES 56**.
3. Open the mixer to ensure water supplies have been isolated correctly and no water flows from the outlet prior to servicing mixer.

The SQX ATM606 strainers and check valves can be found within the Basin Mount. Access to the Strainers can be obtained after the SQX thermostatic cartridge is removed and the basin spout is lifted off the Basin hob.

IMPORTANT: DO NOT TAKE CARTRIDGE APART

4. Using a long M5 allen key unwind the internal basin mount fixing screw found in lower cavity of the mixer. Once loose carefully lift basin spout off basin Hob. **IMAGES 60 and 61**



IMAGE 60



IMAGE 61

STRAINERS, CHECK VALVES AND HOB MOUNT O-RINGS ATM 606/607 MODELS

1. Ensure both Hot and Cold water supplies have been isolated by turning both Isolation valves 90 degrees to 'OFF' position - refer to **IMAGES 56** (page 21). Open mixer to ensure water supplies have been isolated correctly and no water flows from outlet prior to servicing mixer. Remove basin Body as per instructions on previous page.
2. Using an M6 allen key, unscrew hot and cold inlet fittings to gain access to the internal cavities within basin mount **SEE IMAGE 62**.
3. Once removed, check sealing O-rings for damage or debris and replace if needed.
4. Remove strainers from within cavity **SEE IMAGE 63**. Strainers should be cleaned with a diluted de-scaling solvent (such as CLR), checked for physical damage and thoroughly rinsed with clean water.
5. The check valves are located within both the hot and cold inlet fittings **SEE IMAGE 64** Using circlip pliers, remove circlips from both fittings
6. Using a small allen key, gently push out check valves. The Check Valves should be cleaned with a dilute water solution of suitable de-scaling solvent (such as CLR), checked for physical damage and then thoroughly rinsed with clean water.
7. The Hob Mount O-rings are found around the base of the Hob mount. While the Mixer body is removed from Basin Mount, it is possible to check these O-rings for damage or debris. Additionally it is possible to check that the Hot inlet Fitting O-ring and Central mount O-ring for damage. **SEE IMAGE 65**
8. Re-fit strainers and inlet fittings, ensuring the taller 'HOT' inlet fitting is screwed into the correct Hot supply cavity **SEE IMAGE 62**.
9. **Check each fittings location within hob mount corresponds to Hot and Cold markings on base of hob mount SEE PAGE 5 & 6 for details for ATM606/607 models.**
10. Re-fit mixer body over Basin mount, ensuring O-rings do not pinch or get caught on isolation valve access cavity. Using M5 allen key, thread in basin mount fixing screw, until the basin body is firm against the basin top - ensuring both O-rings are correctly positioned and lightly greased.
11. When service is complete, slowly open the cold water isolation valve and inspect mixer body for leaks. Repeat with Hot water isolation valves. Open mixer by rotating handle anti clockwise and check operation and flow.
12. Commence commissioning as per instructions on page 19.

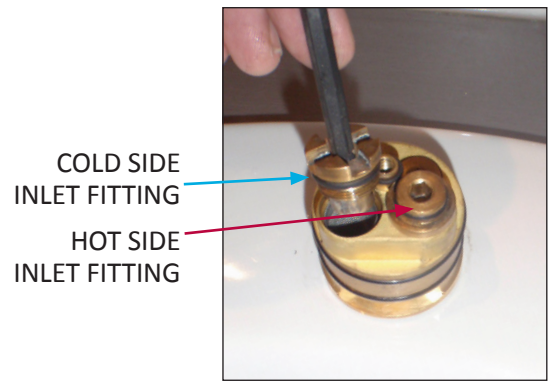

IMAGE 62

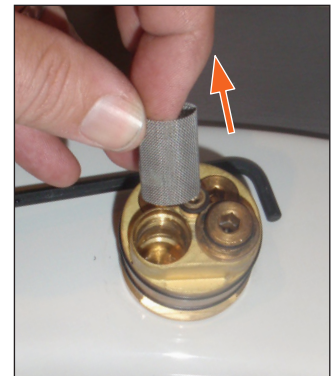

IMAGE 63



IMAGE 64



IMAGE 65

- ① Ensure all O-rings are slightly greased before re-fitting basin body.
- ② Ensure fittings are wound down flat against hob mount

SWIVEL SPOUT SEALING O-RINGS

ATM607 / 610X / 611 MODELS

1. Swivel Spout O-rings seals can be checked/replaced without isolating the water supply. Ensure the mixer is turned off **SEE IMAGE 34** on page 15 with the handle fully rotated in the clockwise direction.
2. Remove handle by unscrewing the allen key locking pin on the side of the handle. Once the locking pin is removed, carefully lift the handle straight up out of position off the cartridge spline.
SEE IMAGE 28 on page 14.
3. Loosen the head grub screw, located at the back of the swivel spout, use an M5 allen key **SEE IMAGE 66**
4. The swivel spout can then be removed by pulling off vertically, however rotating the spout may assist in this process. **SEE IMAGE 67**
5. Once removed O-rings can be checked for wear, damage or debris and replaced if required.
6. Re-install Swivel Spout over mixer body ensuring O-rings have been re-greased. Wind in M5 grub screw until it is flush with back surface of Swivel Spout.
CAUTION: Do not wind grub screw in too far
7. Turn mixer on to test for leaks and swivel operation of spout.



IMAGE 66



IMAGE 67

STRAINER & CHECK VALVE ASSEMBLY

ATM610X / ATM611 Models

1. The Strainers and Check Valves within the body can be easily accessed via the removal of the Strainer covers at each end of the mixer's breech once both Hot and Cold water supplies have been isolated.
2. Ensure both the Hot and Cold water supplies have been isolated by turning both Isolation valves 90 degrees into their 'OFF' position. Open the mixer to ensure water supplies have been isolated correctly and no water flows from the outlet prior to servicing mixer.
3. Using the SQX prong tool, unwind the Strainer covers and remove to one side, being careful not to scratch Chrome surface **SEE IMAGE 68**.
4. Use an M10 allen key, unscrew the strainer/check valve assembly and remove from mixer **SEE IMAGE 69**.
Once removed check sealing O-rings for damage or debris and replace if needed. The strainer/check valve assembly should be cleaned with a dilute water solution of suitable descaling solvent (such as CLR), checked for physical damage and then thoroughly rinsed with clean water.
5. Re-fit strainer/check valve assembly ensuring the O-rings have been lightly greased and then fit Strainer covers. Turn on water supplies and test for leaks. Commence commissioning as stated on page 19.



IMAGE 68

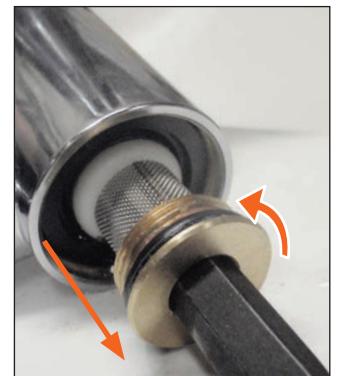

IMAGE 69

troubleshooting

Refer to the following troubleshooting /fault-finding chart for specific problems and solutions. Service instructions are supplied with spare part kits

	FAULT / SYMPTOM	CAUSE	RECTIFICATION
1	The desired mixed water temperature cannot be obtained or valve is difficult to set.	<ul style="list-style-type: none"> Hot and cold supplies are fitted to wrong connections Thermostatic cartridge contains debris or damaged Strainers contain debris Non-return devices are damaged 	<ul style="list-style-type: none"> Refit the valve with Hot/Cold supplies fitted to the correct connections Replace cartridge Clean strainers ensuring debris is removed Check non-return device is not jammed Clean or replace it if necessary
2	The thermostatic mixing valve will not thermally shut down	<ul style="list-style-type: none"> Hot to mix temperature differential is not 10°C or greater Thermostatic cartridge contains debris or damaged Non-return devices are damaged 	<ul style="list-style-type: none"> Raise hot water temperature Replace cartridge Check non-return device is not jammed Clean or replace it if necessary
3	Mix temperature unstable	<ul style="list-style-type: none"> Flow rate below 2L/min. Thermostatic cartridge contains debris or damaged Strainers contain debris Non-return devices are damaged 	<ul style="list-style-type: none"> Rectify any pressure deterioration Replace cartridge Clean strainers ensuring debris is removed Check non-return device is not jammed Clean or replace it if necessary
4	Mix temperature changing over time	<ul style="list-style-type: none"> Inlet conditions (pressures or temperatures) are fluctuating Strainers contain debris 	<ul style="list-style-type: none"> Install suitable pressure control valves to ensure inlet conditions are within those stated on page 4 Clean strainers ensuring debris is removed
5	Water is leaking from mixer body	<ul style="list-style-type: none"> Mixer body o-rings are worn or damaged or contain debris. 	<ul style="list-style-type: none"> Replace strainer body o-rings (ATM611) Replace Swivel Spout sealing o-rings (ATM607/610X / 611) Replace basin hob sealing o-ring (ATM606/607)
6	Either full hot or cold flowing from outlet fixture	<ul style="list-style-type: none"> Upper temperature ring incorrectly set. Hot/Cold water has migrated to other inlet Damaged check valves Refer also to fault/symptom 1 & 2 	<ul style="list-style-type: none"> Re-set temperature as per instructions on page 16 to between 35 - 46°C as required Replace faulty check valves
7	Water is not flowing from outlet	<ul style="list-style-type: none"> Hot or cold water failure. Thermostatic cartridge contains debris or damaged Strainers contain debris 	<ul style="list-style-type: none"> Remove aerator and clean then reinstall Restore inlet supplies and check mix temperature Replace cartridge Clean strainers
8	Flow rate reduced or fluctuating	<ul style="list-style-type: none"> Thermostatic cartridge, strainers or inlet fittings fouled by debris Dynamic inlet pressures are not within recommended limits 	<ul style="list-style-type: none"> Check Thermostatic cartridge, strainers and inlet fittings for blockages Ensure operating conditions are within specified limits and the dynamic inlet pressures are balanced to within +/- 10%
9	Mixed water temperature too hot or cold	<ul style="list-style-type: none"> Upper temperature ring is incorrectly set or tampered with Inlet temperatures are not within specified limits 	<ul style="list-style-type: none"> Re-set temperature as stated on page 16 to between 35 - 45°C as required Ensure inlet temperatures are within the specified limits of 55 - 85°C for Hot; and 5 - 25°C for Cold.
10	Mixed water temperature doesn't change when the handle is rotated.	<ul style="list-style-type: none"> Thermostatic cartridge contains debris, has failed or is damaged. 	<ul style="list-style-type: none"> Clean the Cartridge ensuring that all debris is removed and components are not damaged. Replace if necessary
11	Leaking from outlet	<ul style="list-style-type: none"> Cartridge is damaged or O- rings split. Supply pressures too high Cartridge has come loose in mixer body. Thermostatic cartridge contains debris or damaged. 	<ul style="list-style-type: none"> Check pressure & install a pressure reduction valve Ensure Thermostatic cartridge is tightened to 10nm in mixer body Replace cartridge
12	Water comes on when handle is in closed position	<ul style="list-style-type: none"> Mixer has been installed incorrectly or not tightened to a firm stop. 	<ul style="list-style-type: none"> Re-install or replace cartridge. Refer to service instructions on page 21

Enware Australia Pty Limited (ACN 003 988 314) (“we” or “us”) warrants that this product (also referred to as “our goods”) will be free from all defects in materials and workmanship for 5 years* from the date of purchase. Our liability under this warranty is limited at our option to the repair or replacement of the defective product or part, the cost of repair of the defective product or part or the supply of an equivalent product or part, in each case if we are satisfied the loss or damage was due to a defect in the materials or workmanship of the product or part. All products must be installed in accordance with the manufacturer’s instructions, the PCA, and AS/NZS3500 including any other applicable regulatory requirements.

making a claim

To make a claim under this warranty you must notify us in writing within 7 days of any alleged defect in the product coming to your attention and provide us with proof of your purchase of the product together with a completed Online Product Service and Warranty Form, available from our website www.enware.com.au/warranty.

All notifications and accompanying forms must be sent to us marked for the attention of the Enware Australia Pty Limited, 9 Endeavour Road, Caringbah NSW 2229. We can also be contacted by telephone (1300 369 273) or by email (info@enware.com.au). Your costs in making a claim under this warranty, including all freight, collection and delivery costs, are to be borne and paid by you. We also reserve the right at our cost to inspect any alleged defect in the product wherever it is located or installed or on our premises.

* 5 Years Conditional Warranty: 2 years parts and labour on the complete assembly; an additional 3 years, parts supply only, on the thermostatic cartridge component assembly

exceptions

This warranty does not apply in respect of any damage or loss due to or arising from:

- a) Failure by you or any other person to follow any instructions for use (including instructions and directions relating to the handling, storage, installation, fitting, connection, adjustment or repair of the product) published or provided by us;
 - b) Failure by you or any other person responsible for the fitting, installation or other work on the product to follow or conform to applicable laws, standards and codes (including the AS/NZ 3500 set of Standards, all applicable State and Territory Plumbing Codes, the Plumbing Code of Australia and directions and requirements of local and other statutory authorities); or
 - c) Any act or circumstance beyond our control including faulty installation or connection, accident, abnormal use, acts of God, damage to buildings, other structures or infrastructure and loss or damage during product transit or transportation.
-

other conditions

Except as provided or referred to in this document, we accept no other or further liability for any damages or loss (including indirect, consequential or economic loss) and whether arising in contract, tort or otherwise. Any benefits available to you under this warranty are in addition to any non-excludable rights or remedies you may have under applicable legislation, including as a “consumer” under the Australian Consumer Law. To that extent you need to be aware that: Our goods come with guarantees that cannot be excluded under the Australian Consumer Law. You are entitled to a replacement or refund for a major failure and for compensation for any other reasonably foreseeable loss or damage. You are also entitled to have the goods repaired or replaced if the goods fail to be of acceptable quality and the failure does not amount to a major failure.

Aquablend SQX Thermostatic Mixing Valve Commissioning and/or Maintenance Report

PRINT ALL DETAILS or MARK WITH AN ⊗ IN BOXES IN BOXES TO INDICATE CHOICE

1. In all cases the Licensee is to submit this report within seven working days after commissioning and/or servicing the valve.
2. Use a separate form for each valve.
3. The original report is to be given to the owner/occupier and retained on site for a minimum of 7 years.
4. All details are to be filled in. Incomplete reports will not be accepted.

Name of Establishment					
Street Address					
Suburb		State	Post Code		
Phone #		Contact Name			
Date		Work Order No.			
Make & Model of Hot Water Unit					
Make of Mixing Valve		Model No			
		Size			
Valve ID No.		Total No. of Mixing Valves on Site/Building			
Valve Location / Building					
Area serviced by valve					
Outlet Type mark with ⊗	Bath		Basin		Shower

Valve installed to requirements of:		
1. The local water supply authority	2. The valve manufacturer /supplier requirements	3. The Australian Standards for Plumbing and Drainage
<input type="checkbox"/> YES <input type="checkbox"/> NO	<input type="checkbox"/> YES <input type="checkbox"/> NO	<input type="checkbox"/> YES <input type="checkbox"/> NO
If NO, give details and action taken:		

Hot Water	Pressure	kPa	Cold Water	Pressure	kPa
	Temp	°C		Temp	°C
Cold Water Supply via			Pressure Reducing Valve Fitted	<input type="checkbox"/> YES <input type="checkbox"/> NO	
Details of work carried out (mark with ✓)			<input type="checkbox"/> Serviced <input type="checkbox"/> Visually inspected & clean valve components <input type="checkbox"/> Replaced o-rings and lubricate <input type="checkbox"/> Set temperature	<input type="checkbox"/> Commissioned <input type="checkbox"/> Checked function of non return valve <input type="checkbox"/> Reassemble <input type="checkbox"/> Dismantle <input type="checkbox"/> Thermal shut down test	
List of items replaced and part numbers during this visit			Service Kit No.		
			Other Parts		
Temperature range of warm water at outlet (please ✓)				°C Set	
<input type="checkbox"/> Neonatal and children 38-40°C <input type="checkbox"/> Adult 40.5-43.5°C				Temperature	

Date of this service /commissioning:		Date of next due service	
Date of Previous service		Carried out by	
Date Valve Installed		Valve installed by	

It is hereby certified that all the commissioning work has been carried out by the undersigned in accordance with local plumbing requirements for Thermostatic Mixing Valves

Contractor Business Name			
Contractor Name (please print)		Contractor Lic/Cert No	
Licensed Plumber (Signature)		Date	
Contractors Phone No			
Owner/Occupier Signature		Date	

A duplicate copy of this report is to be retained at the site for any inspection by authorised persons



ADDRESS: 9 Endeavour Road, Caringbah NSW 2229 Australia

POSTAL ADDRESS: P.O. Box 2545, Taren Point NSW 2229 Australia

PHONE: 61 2 8536 4000 **FAX:** 61 2 8556 4066

1300 369 273 (AUS) WWW.ENWARE.COM.AU INFO@ENWARE.COM.AU

