

# Wall Mounted Sensor Tap - Hands-Free On / Off Demand Sensor

## EMW803A

The Touch Free Wall Mounted Sensor is a wall-mounted, sensor operated, hands-free tap that is installed above sinks and basins. It operates by sensing a hand, placed within 5 cm of the sensor unit. It uses a beam of invisible Infrared light which, when reflected from hand back to the sensor, operates the unit.

### FEATURES

- To turn tap on, place hand in front of sensor for half a second
- To turn tap off, place hand in front of sensor again for half a second
- Valve stays open without hand remaining in the beam
- Maximum flow time 45 seconds\* reduces waste and overflow if accidentally activated
- Equipped with automatic hygiene flush function (1-10min/24hr) - enabled on request\*
- Stainless steel sensor plate
- Separate spout

\* Longer flow times and other program settings are available at the time of ordering. Contact Enware for more information.



### Product Codes

<b>EMW803A-150</b>	Wall Mounted Sensor Tap - On / Off Demand system with 150mm spout
<b>EMW803A-200</b>	Wall Mounted Sensor Tap - On / Off Demand system with 200mm spout
<b>EMW803A-LO</b>	Wall Mounted Sensor Kit - On / Off Demand system (less outlet spout)

### Technical Information

Inlet Connection	15 mm (1/2") BSP
Recommended Working Pressure	100 - 500 kPa*
Flow Rate	4 star (7.7 lpm) WELS rating supplied standard. 6 Star (5.6 lpm), 5 Star (6.2 lpm) WELS ratings available on request.
Maximum Temperature	70 °C *
Operating Voltage	24V DC
Maximum Current	1A
Power Consumption	Less than 10W
Sensor Min / Max Ambient Temperature	Minimum: -5 °C, Maximum: 50 °C
Sensor Protection Rating	IP67 for the front panel and sensor lens. No IP rating behind panel.
Sensor Range	20 - 100mm
Flow Time	Place hand in sensor range to activate. Place hand in sensor range again to stop. Maximum of 45 seconds time out per activation.

\*Enware products are to be installed in accordance with the Plumbing Code of Australia (PCA) and AS/NZS3500. Installations not complying with PCA and AS/NZS 3500 may void the product and performance warranty provisions.

Reference should also be made to the Australasian Health facility Guidelines (AHFG), ABCB and Local Government regulations when considering the choice of, and the installation of these products.

NOTE: Enware Australia advises:

1. Due to ongoing Research and Development, specifications may change without notice.
2. Component specifications may change on some export models.

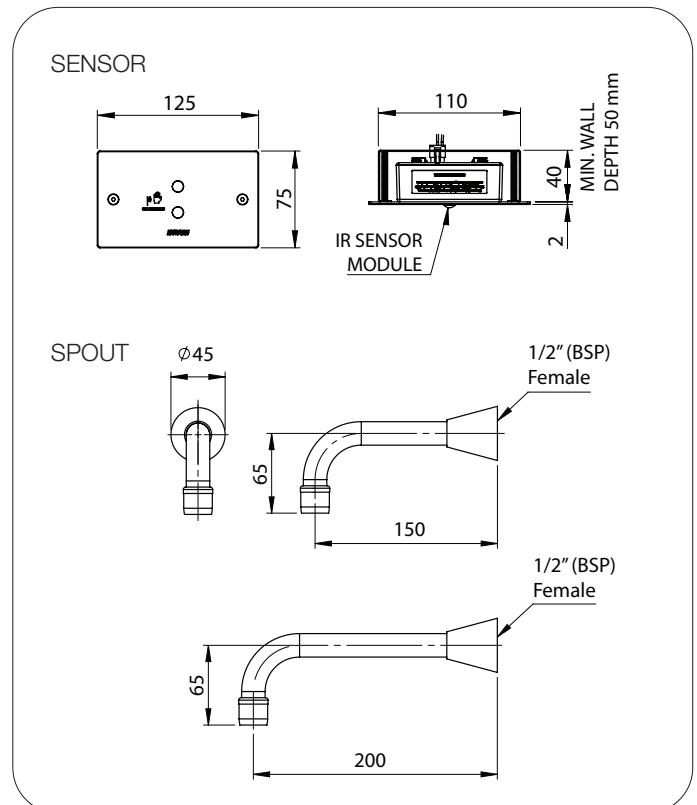

Version: Oct 20

Call 1300 369 273  
www.enware.com.au

Enware Australia Pty Limited  
9 Endeavour Rd Caringbah NSW 2229 Australia  
Ph: 02 8536 4000 info@enware.com.au

