

ANTI VANDAL TAPWARE

Installation Instructions

CONCEALED SPINDLE (CS) SERIES

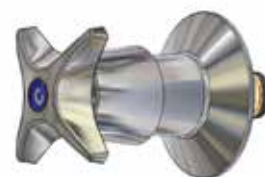

SCHOOL PATTERN (VP) SERIES



TRADITIONAL/INSTITUTIONAL (IN) SERIES



PLAZA (PZ) SERIES



contents

	page
TECHNICAL DATA	3
INSTALLATION COMPLIANCE	3
PRODUCT DIMENSIONS	4
IN WALL ROUGH-IN CHART	6
INSTALLATION & COMPONENTS	
SBA Installation	7
CS Series Recess Adaptors	Installation 8
	Components 9
School Pattern & Traditional Series Recess Adaptors	Installation 10
School Pattern Recess Adaptors	Components 11
Traditional Series Recess Adaptors	Components 12
Plaza Series Recess Adaptors	Installation 13
	Components 14
Basin/Sink Tapware	Installation 15
TROUBLESHOOTING	17
SERVICE AND MAINTENANCE	18
PRODUCT WARRANTY FOR AUSTRALIA	19

technical data

Working Pressure Range Ceramic Disc	50-800kPa 500kPa Max (PCA)*
Working Pressure Range Jumper Valve	30-1200kPa 500kPa Max (PCA)
Maximum Working Temperature*	Ceramic Disc - 85°C Jumper Valve - 95°C

installation compliance

*Enware products are to be installed in accordance with the Plumbing Code of Australia (PCA), AS/NZS3500 and the manufacturer's instructions.

Installations not complying with PCA, AS/NZS 3500 or the manufacturer's instructions may void the product and performance warranty provisions.

This product must be installed and commissioned by a qualified plumber. The following clauses must be observed for a compliant installation and correct operation of Enware tapware.

WATER SERVICES

Plumbing Code of Australia: Part B1 Cold Water Services AS / NZS 3500.1-2003 Water Services;

- Section 1.6(a) Facilities for people with Disabilities
- Section 3.3.2 Pressure at outlets (min 50kPa)
- Section 3.3.4 Maximum pressure within buildings (500kPa static)
- Section 3.4 Velocity Requirement (Max 3.0m/s)
- Section 16 Testing and Commissioning; Flushing, Hydrostatic testing, cleaning and disinfection of water services.

HEATED WATER SERVICES

Plumbing Code of Australia: Part B2 Heated Water Services

AS / NZS 3500.4-2003 Heated Water Services;

- Section 1.9 Water Temperature
 - 1.9.1 Storage Temperature
 - 1.9.2 Sanitary fixtures delivery temperature
 - 1.9.3 Acceptable solutions for control of delivery temperatures
- Section 10 Heated Water Services for People with Disabilities
- Section 11 Testing and Commissioning

product dimensions

CS SERIES

Recess Adaptors

CS308 JUMPER VALVE

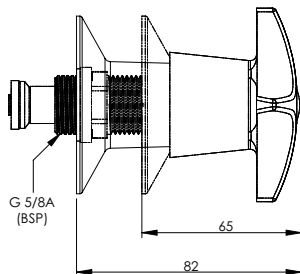

CSQ308 CERAMIC DISC

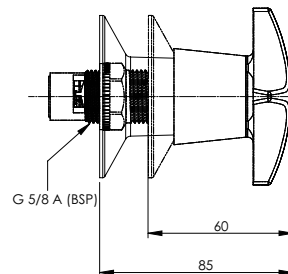

Basin/Sink Assembly

CS391 JUMPER VALVE

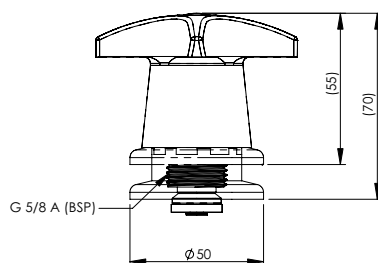

CSQ391 CERAMIC DISC

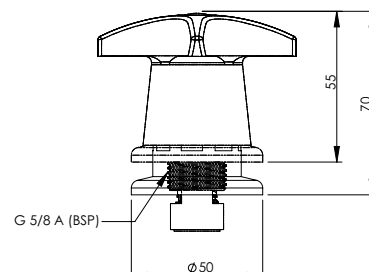

SCHOOL PATTERN SERIES

Recess Adaptors

VP308 JUMPER VALVE

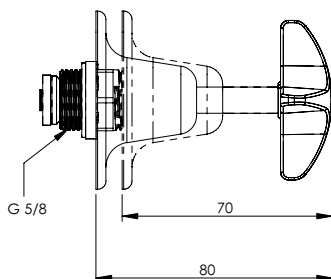

VPQ308 CERAMIC DISC

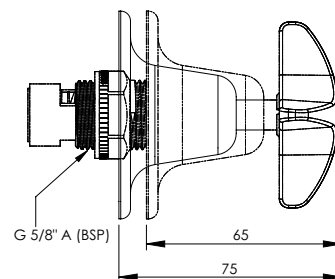

Basin/Sink Assembly

VP391 JUMPER VALVE

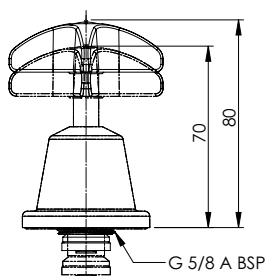

VPQ391 CERAMIC DISC

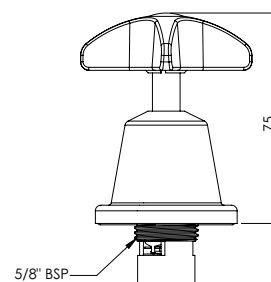

product dimensions

TRADITIONAL SERIES

Recess Adaptors

IN308 JUMPER VALVE

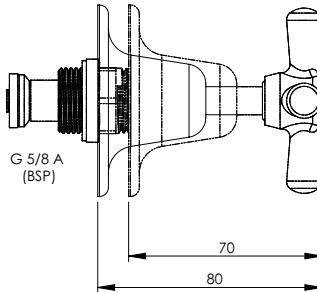

INQ308 CERAMIC DISC

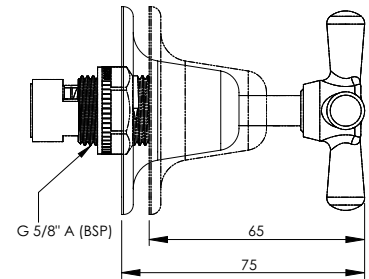

Basin/Sink Assembly

IN391 JUMPER VALVE

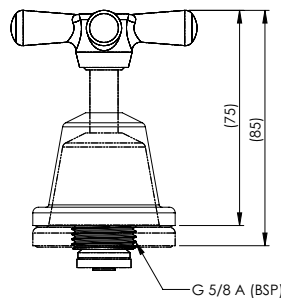

INQ308 CERAMIC DISC

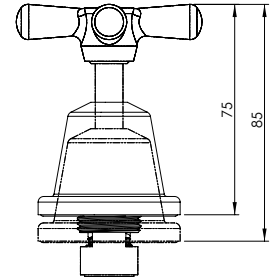

PLAZA SERIES

Recess Adaptors

PZ308 JUMPER VALVE

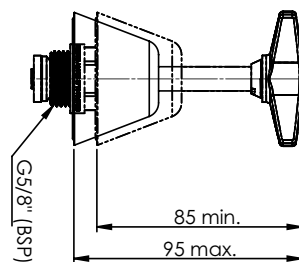

PZQ308 CERAMIC DISC

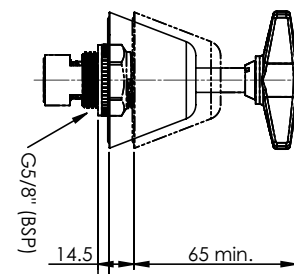

Basin/Sink Assembly

PZ391 JUMPER VALVE

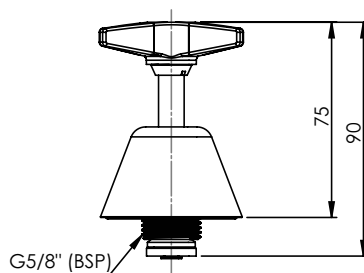

PZQ391 CERAMIC DISC

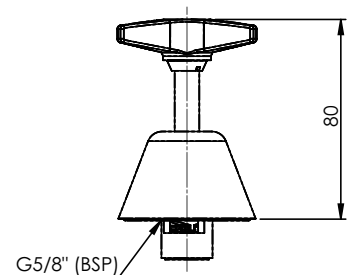

in wall body rough-in chart

WALL DEPTH ADJUSTMENTS

Enware's Recess taps have adjustments for installation flexibility – Spindle Extensions are available in 15, 20, 25, 30, and 40mm.

CS JUMPER VALVE

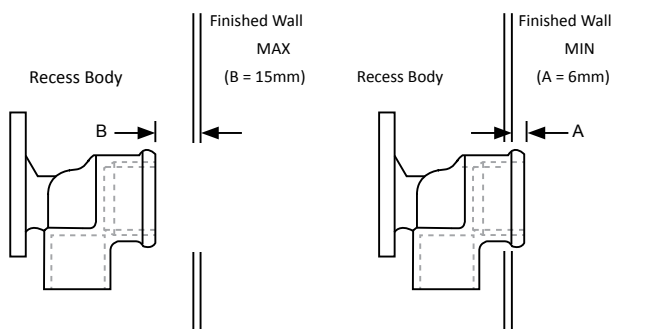

(From 6mm in front of finished wall to 15mm behind finished wall)

CS CERAMIC DISC

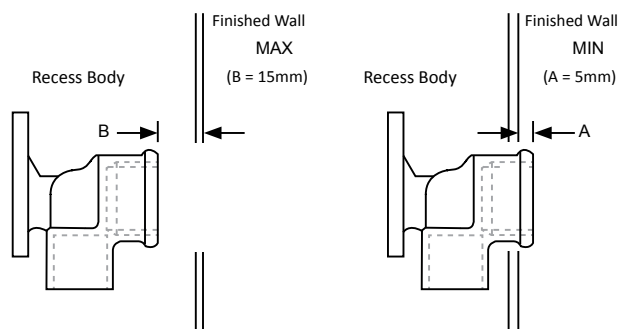

(From 5mm in front of finished wall to 15mm behind finished wall)

SCHOOL PATTERN VP JUMPER VALVE

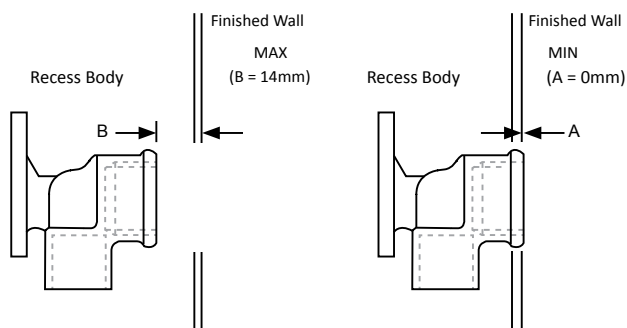

(From level with finished wall to 14mm behind finished wall)

SCHOOL PATTERN VP CERAMIC DISC

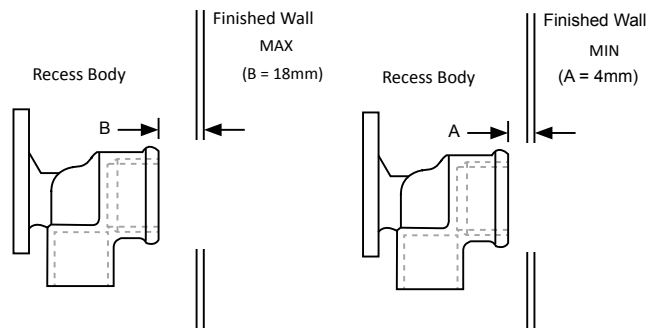

(From 4mm behind finished wall to 18mm behind finished wall)

TRADITIONAL SERIES IN JUMPER VALVE

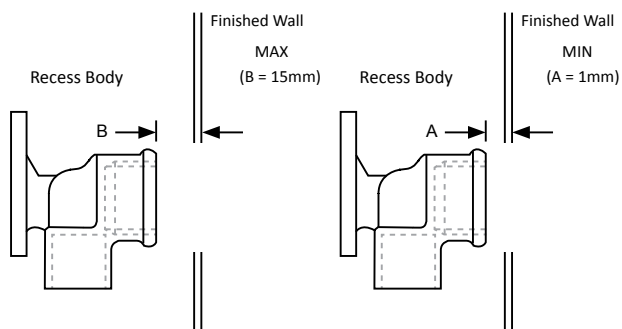

(From 1mm behind finished wall to 15mm behind finished wall)

TRADITIONAL SERIES IN CERAMIC DISC

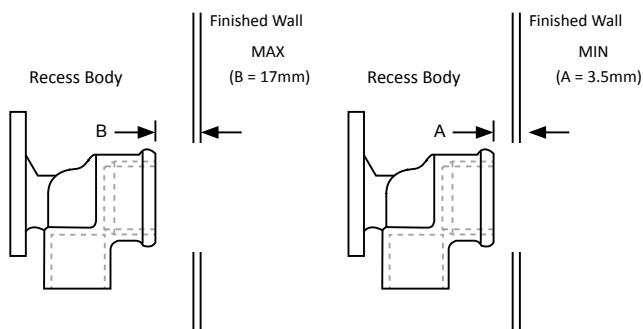

(From 3.5mm behind finished wall to 17mm behind finished wall)

PLAZA SERIES PZ JUMPER VALVE

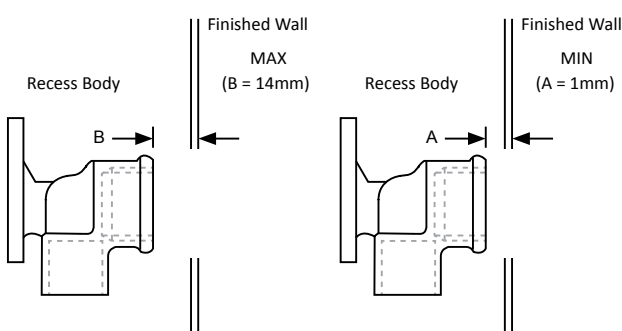

(From 1mm behind finished wall to 14mm behind finished wall)

PLAZA SERIES PZ CERAMIC DISC

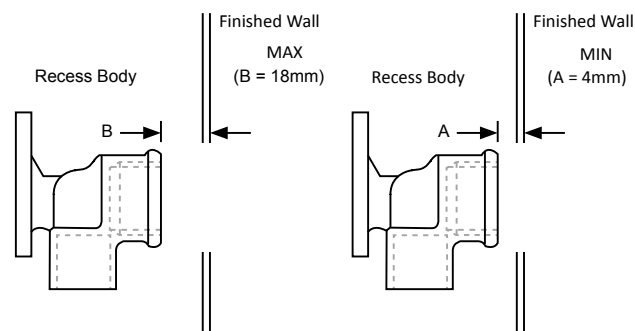

(From 4mm behind finished wall to 18mm behind finished wall)

installation instructions

TOOLS REQUIRED: Enware spanner key, shifting spanner or tube spanner.

SBA INSTALLATION - JUMPER VALVE

1. Remove the stuffing box assembly (SBA) from the packaging. Remove the end cap under the stuffing box assembly
2. Make sure a fibre washer is present beneath the stuffing box. Screw the SBA into the wall body, then use a spanner on the flats of the hex to tighten. Do not tighten SBA by using the spindle. **SEE IMAGE 1**

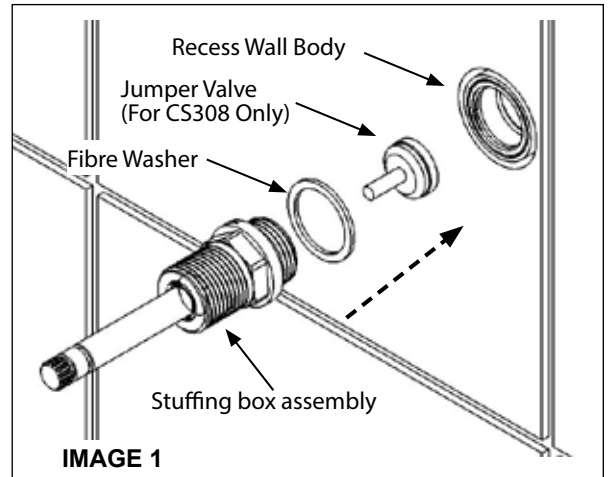

SBA INSTALLATION - CERAMIC DISC

1. Remove the plastic protecting cap from the seat of the Stuffing Box Assembly (SBA) cartridge (where fitted). Remove the fibre washer and unscrew the threaded SBA Locknut from the SBA cartridge. **See IMAGE 2**
2. Hand tighten the SBA cartridge into the wall body. **See IMAGE 3**
3. Using a ring spanner, or where necessary a tube spanner (do not use multi-grips or pliers), turn SBA gently until it comes to a firm stop. Do not over tighten. Do not tighten cartridge by using the spindle.
4. Fit the red fibre washer over the SBA cartridge so it is against the face of the tap body. Now fit the threaded SBA locknut onto the cartridge and screw it up to the face of the tap body, securing the red fibre washer to the tap body. **See IMAGE 4**
5. Using a spanner (ring spanner, or where necessary a tube spanner - do not use multi-grips), tighten the locknut firmly. Recommended torque setting is 30Nm.

TESTING FOR LEAKS FROM SBA:

1. Turn off the SBA's using a handle, then turn water supply on. Turn the tap on and off a few times to test for leaks from SBA's.
2. Once water-tightness is confirmed, seal gaps between the SBA's and the wall with silicone sealant or other appropriate sealant.

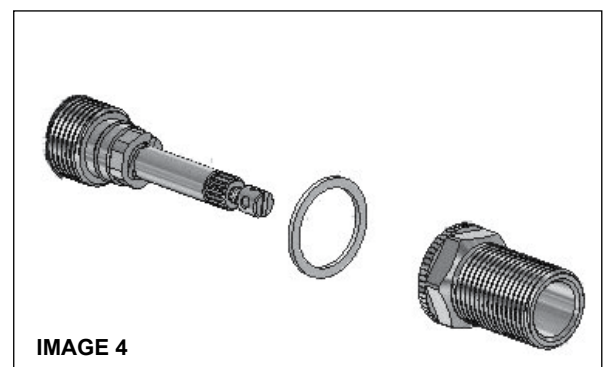
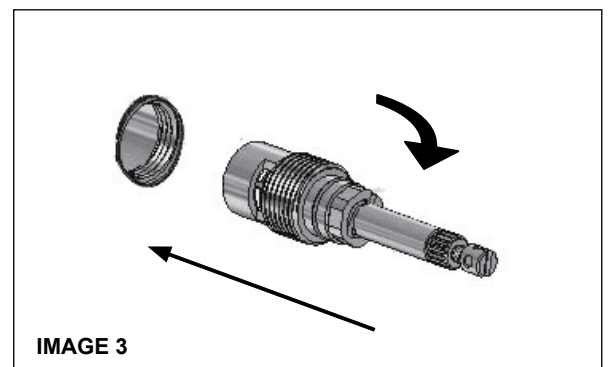
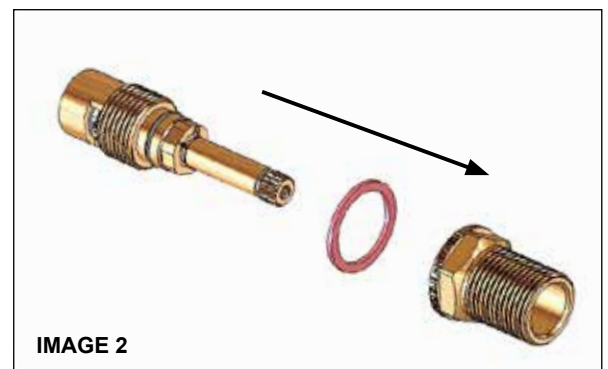

CS SERIES TAPWARE INSTALLATION

1. Screw the flange onto the stuffing box by hand until it sits flat against the wall **SEE IMAGE 5**

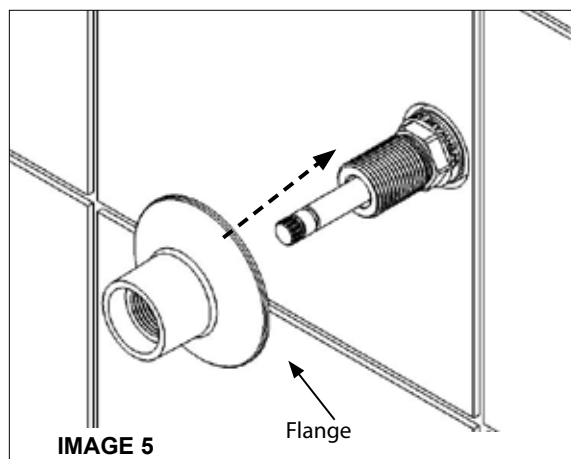

2. Place the skirt onto the spindle
3. Remove the insert and circlip from the packaging, place the insert onto the spindle, and then place the circlip into the groove (second groove from spline) on the spindle **SEE IMAGE 6**

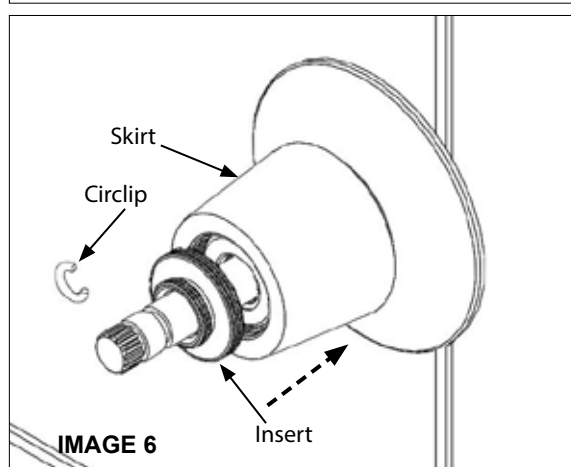

4. Place the handle onto the spline of the spindle, then use the spanner key provided to secure the insert with the bottom of the handle. **SEE IMAGE 7**

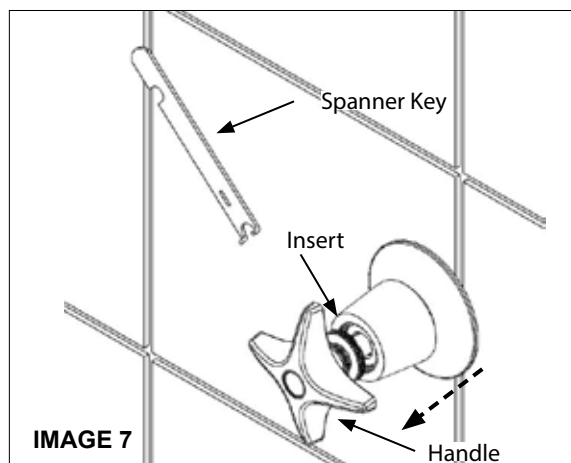

5. Screw the skirting flange to the insert by hand. **SEE IMAGE 8**

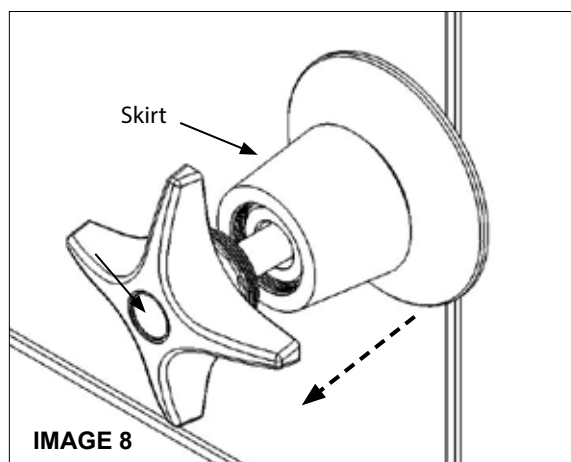

6. Repeat steps for the other recess adaptor
7. Installation completed

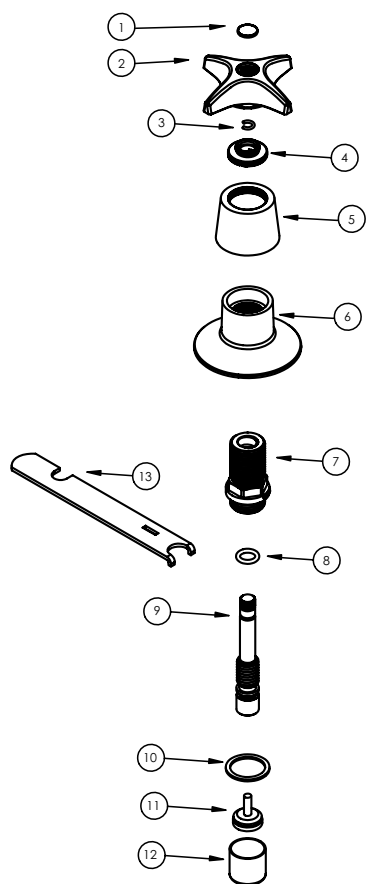

CS JUMPER VALVE

DESCRIPTION		SALES CODE
1	Indicator Button	MIS595
2	Handle	CS378
3	Circlip	
4	Insert	
5	Skirt	
6	Flange	
7	Stuffing Box	CS382
8	Spindle O-Ring	
9	Spindle	
10	Red Fibre Washer	
11	Jumper Valve	
12	End Cap	
13	Anti Vandal Key	MIS590

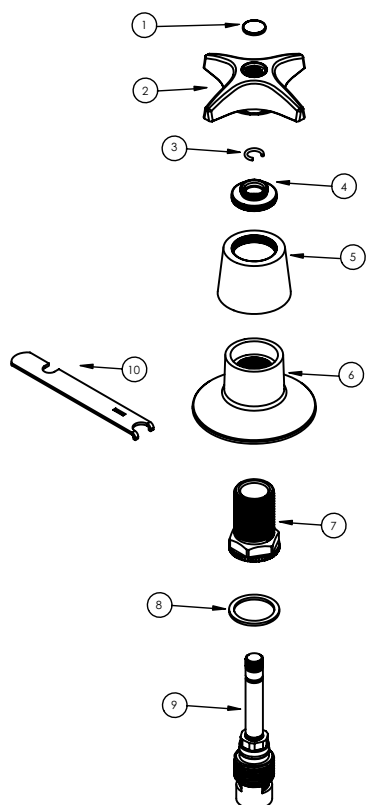

CS CERAMIC DISC

DESCRIPTION		SALES CODE
1	Indicator Button	MIS595
2	Handle	CS378
3	Circlip	
4	Insert	
5	Skirt	
6	Flange	
7	Locknut	CSQ382
8	Red Fibre Washer	
9	Ceramic Cartridge	
10	Anti Vandal Key	MIS590
	Ceramic Disc Service Kit - ¼ Turn	MIS605
	Ceramic Disc Service Kit - ⅜ Turn	MIS606
	Ceramic Disc Service Kit - ½ Turn	MIS610H
	Basin Ceramic Disc Cartridge	CSQ380
	Recess Ceramic Disc Cartridge ¼ Turn	891400
	Recess Ceramic Disc Cartridge ½ Turn	891385

SCHOOL PATTERN - TRADITIONAL - INSTITUTIONAL SERIES RECESS ADAPTOR INSTALLATION

1. Screw the flange onto the stuffing box by hand until it sits flat against the wall **SEE IMAGE 9**

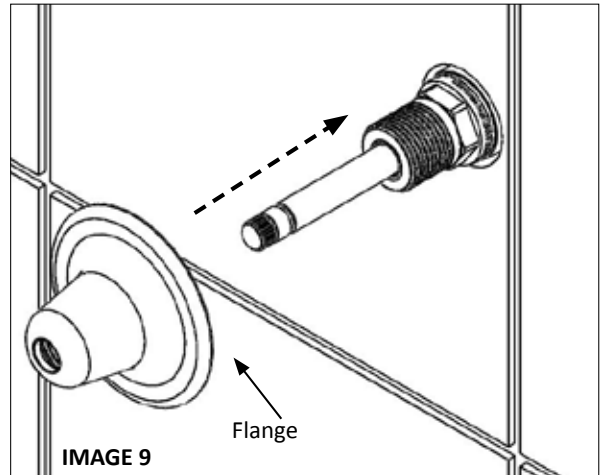

2. Remove the insert and circlip from the packaging, place the insert onto the spindle, and then place the circlip in the groove on the spindle **SEE IMAGE 10**

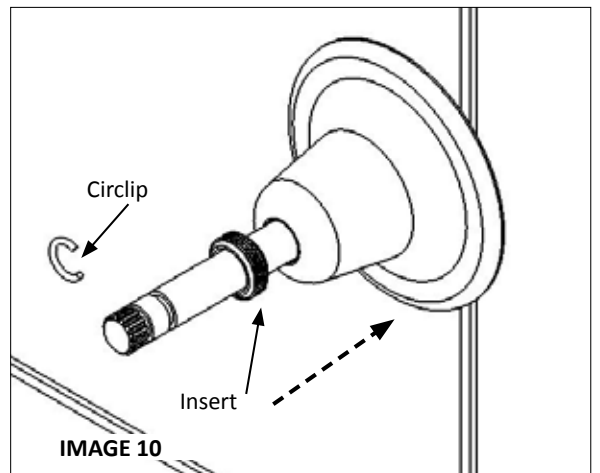

3. Place the handle onto the spline of the spindle, then use the spanner key provided to secure the insert with the bottom of the handle. **SEE IMAGES 11 and 12**

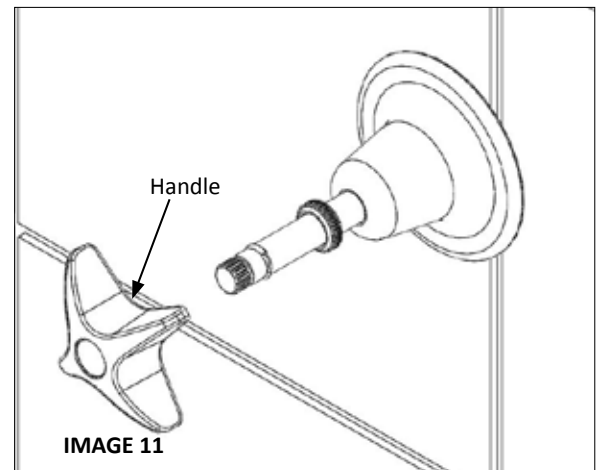

4. Repeat steps for the other recess adaptor
5. Installation completed

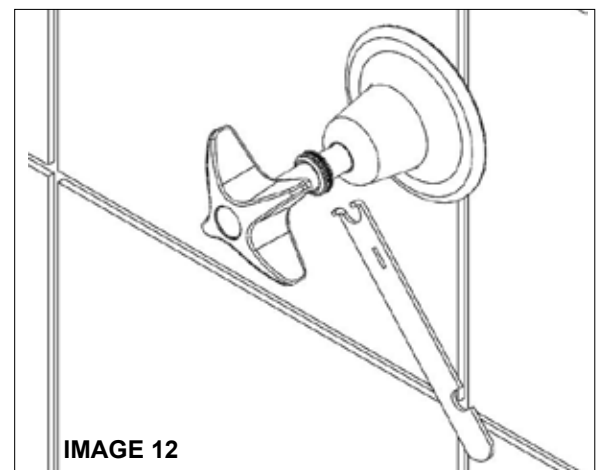

VP JUMPER VALVE

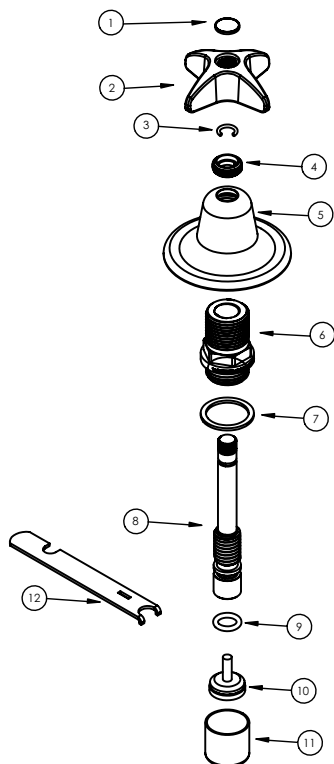

DESCRIPTION		SALES CODE
1	Indicator Button	MIS595
2	Handle	VP378
3	Circlip	
4	Insert	
5	Flange	VP382
6	Stuffing Box	
7	Red Fibre Washer	
8	Spindle	
9	Spindle O-Ring	
10	Jumper Valve	
11	End Cap	MIS590
12	Spanner	

VPQ CERAMIC DISC

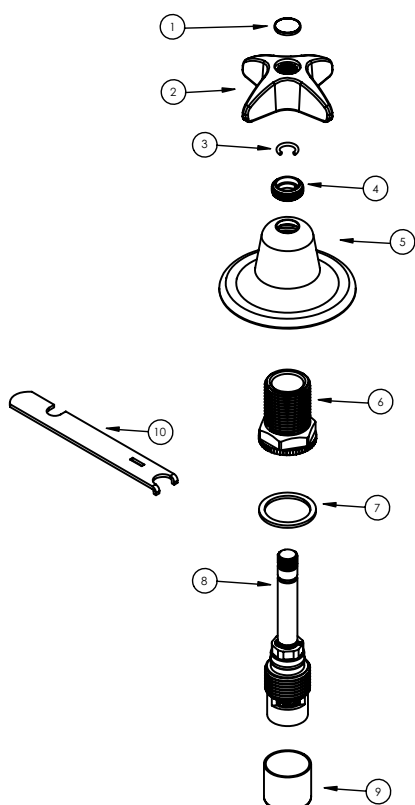

DESCRIPTION		SALES CODE
1	Indicator Button	MIS595
2	Handle	VP378
3	Circlip	
4	Insert	
5	Flange	VPQ382 suitable for basin, bib and recess
6	Locknut	
7	Red Fibre Washer	
8	Ceramic Cartridge	
9	End Cap	
10	Spanner	
	Ceramic Disc Service Kit - ¼ Turn	MIS605
	Ceramic Disc Service Kit - ¾ Turn	MIS606
	Ceramic Disc Service Kit - ½ Turn	MIS610H
	Recess Ceramic Disc Cartridge ¼ Turn	891400
	Recess Ceramic Disc Cartridge ¾ Turn	891385

VP JUMPER VALVE

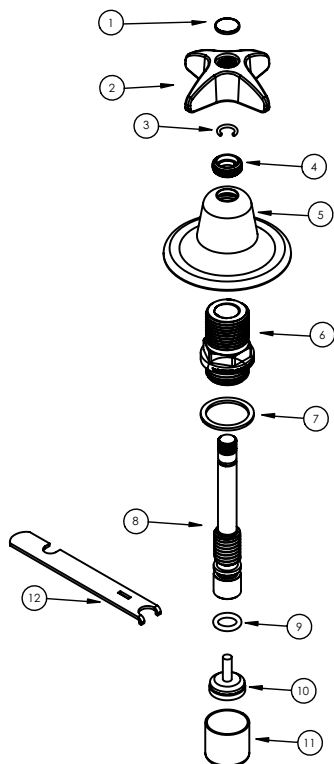

DESCRIPTION		SALES CODE
1	Indicator Button	MIS595
2	Handle	VP378
3	Circlip	
4	Insert	
5	Flange	VP382
6	Stuffing Box	
7	Red Fibre Washer	
8	Spindle	
9	Spindle O-Ring	
10	Jumper Valve	
11	End Cap	
12	Spanner	MIS590

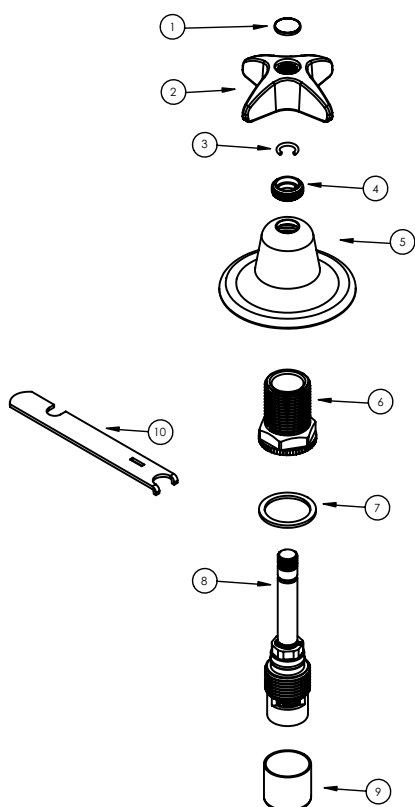

VPQ CERAMIC DISC

DESCRIPTION		SALES CODE
1	Indicator Button	MIS595
2	Handle	VP378
3	Circlip	
4	Insert	
5	Flange	VPQ382 suitable for basin, bib and recess
6	Locknut	
7	Red Fibre Washer	
8	Ceramic Cartridge	
9	End Cap	
10	Spanner	MIS590
	Ceramic Disc Service Kit - ¼ Turn	MIS605
	Ceramic Disc Service Kit - ¾ Turn	MIS606
	Ceramic Disc Service Kit - ½ Turn	MIS610H
	Recess Ceramic Disc Cartridge ¼ Turn	891400
	Recess Ceramic Disc Cartridge ¾ Turn	891385

PLAZA SERIES INSTALLATION

- Place base o-ring under flange and screw the flange onto the stuffing box by hand until it sits flat against the wall.
SEE IMAGE 13

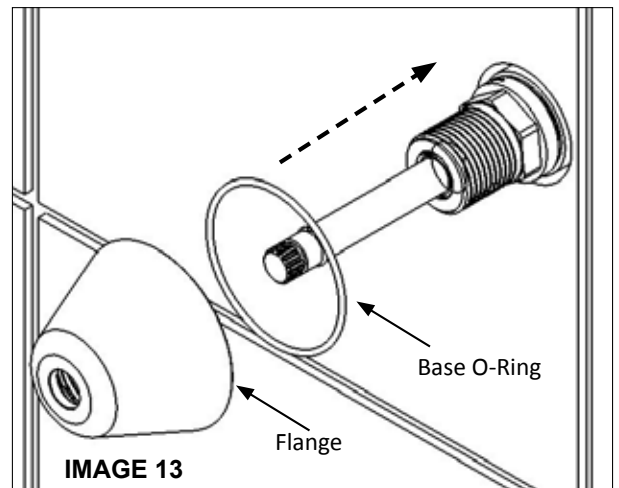

- Remove the insert and circlip from the packaging, place the insert onto the spindle, and then place the circlip in the groove on the spindle.
SEE IMAGE 14

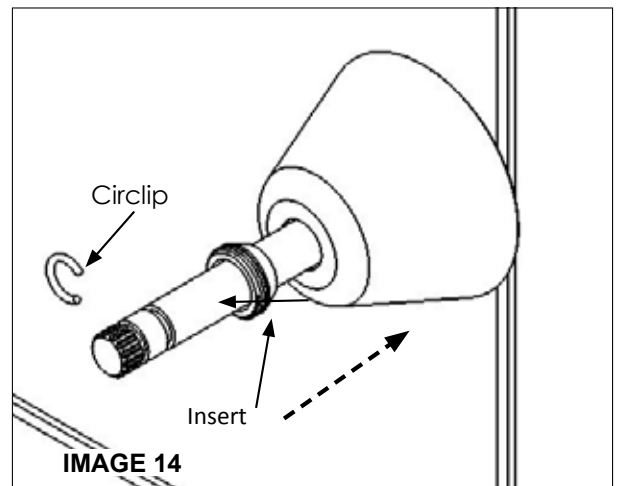

- Place the handle onto the spline of the spindle, then use the spanner key provided to secure the insert with the bottom of the handle.
SEE IMAGE 15

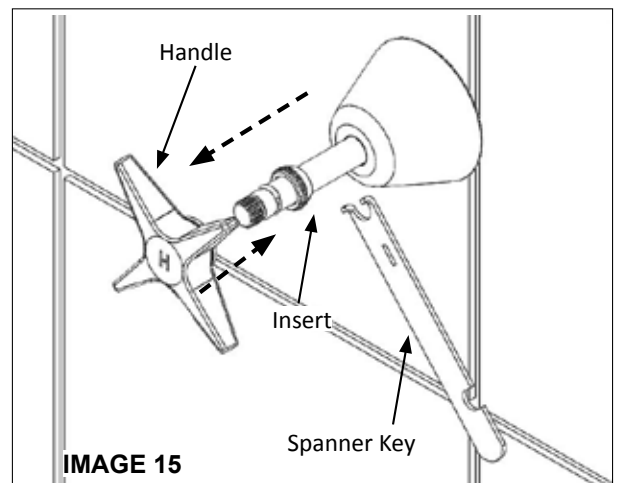

- Repeat steps for the other recess adaptor

- Installation completed

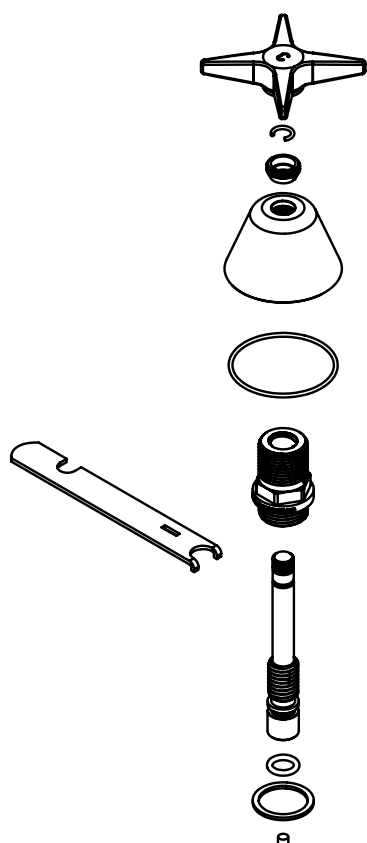

PZ JUMPER VALVE

DESCRIPTION		SALES CODE
1	Handle	PZ378
2	Circlip	
3	Insert	
4	Flange	PZ382
5	Stuffing Box	
6	Spindle	
7	Spindle O-Ring	
8	Red Fibre Washer	
9	Jumper Valve	MIS590
10	End Cap	
11	Spanner	
12	Base O-Ring	

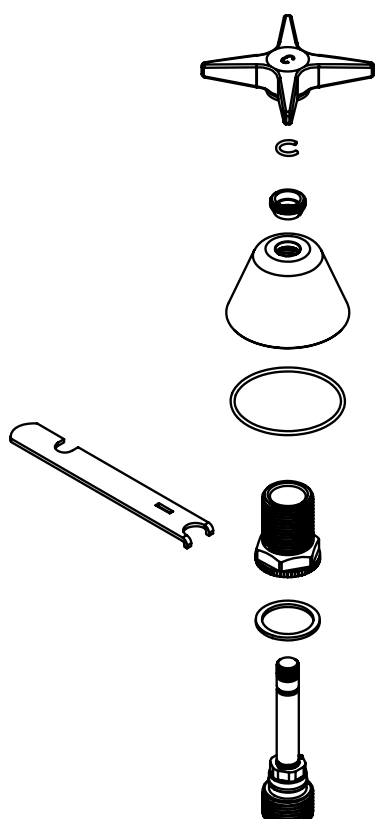

PZ CERAMIC DISC

DESCRIPTION		SALES CODE
1	Handle	PZ378
2	Circlip	
3	Insert	
4	Flange	PZQ382 suitable for basin, bib and recess
5	Locknut	
6	Red Fibre Washer	
7	Ceramic Cartridge	
8	End Cap	MIS590
9	Spanner	
10	Base O-Ring	
	Ceramic Disc Service Kit - ¼ Turn	MIS605
	Ceramic Disc Service Kit - ¾ Turn	MIS606
	Ceramic Disc Service Kit - ½ Turn	MIS610H
	Recess Ceramic Disc Cartridge ¼ Turn	891400
	Recess Ceramic Disc Cartridge ¼ Turn	891385

Tools Required: Spanner or adjustable spanner, basin spanner, threadseal tape or equivalent, copper tube cutter.

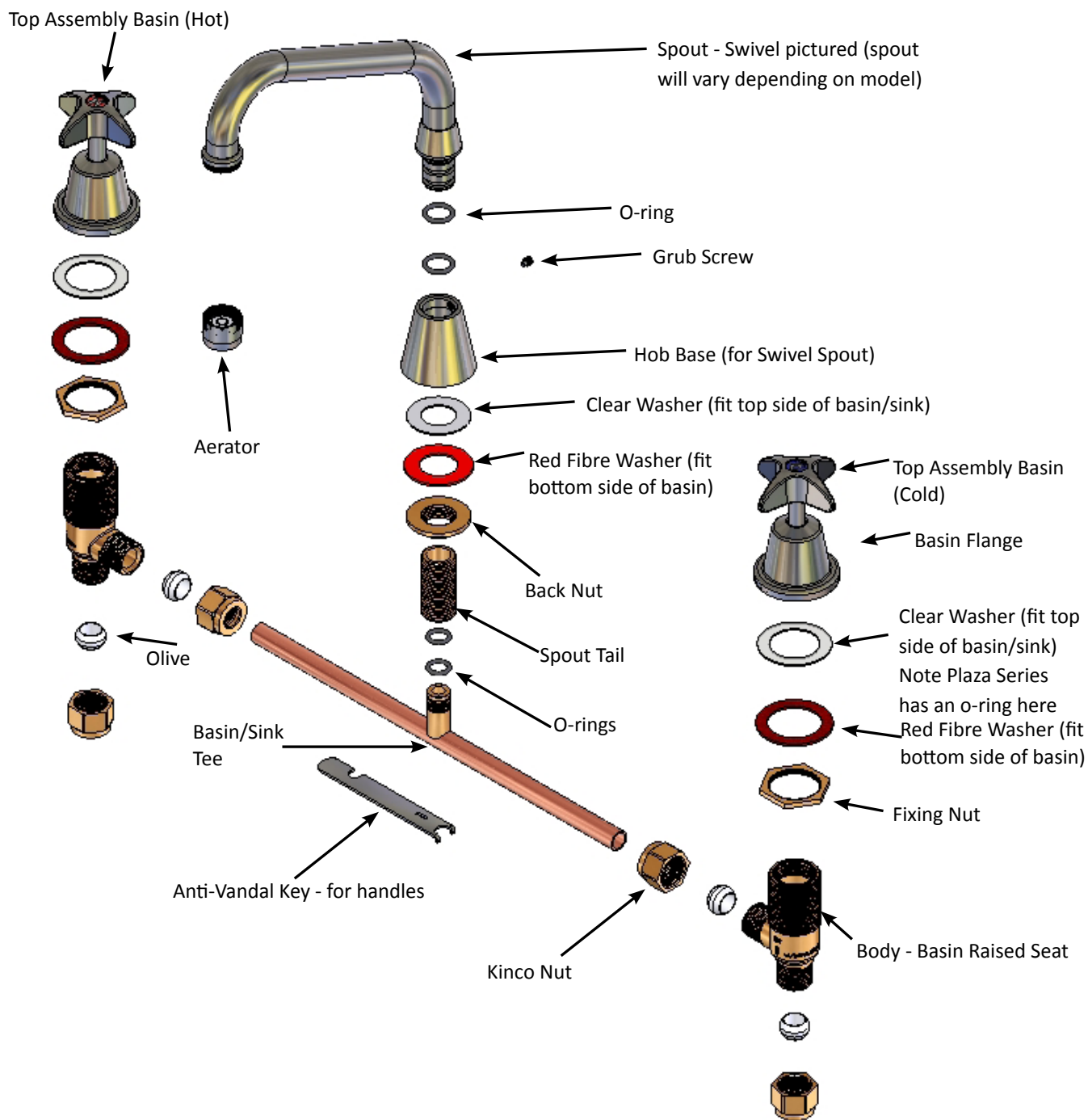

IMAGE 16 Exploded component view | Shown with VP handles and 307 sink spout | Handle type or spouts will vary between models

1. **Basin/Sink Tail and Spout** The non-beveled end only of the spout tail is to be screwed into the base of the spout. Use a thread seal tape or equivalent to seal the joint.

The spout can then be fitted to the basin/sink securing with the backnut. Ensure the clear washer is located above the basin/sink and the red fibre washer is below.

Refer to **IMAGE 16** on page 15

2. Thread fixing nut on to each basin body and have red fibre washer ready for step 3.

3. Measure the tee by loosely fitting the basin bodies into the basin/sink. If holes are required to be drilled refer to **IMAGE 17**.

Position the tee spigot inline with the spout tail.

Measure the distance between the basin bodies, allowing 15mm on each side to protrude into the basin body thread. Cut to size with tube cutters and de-burr both ends.

Insert both ends of the basin tee into the basin bodies with kinco nuts and olives in correct position (refer to **IMAGE 16** on page 15) and hand tighten to the basin bodies.

4. Fit the tee to the spout tail, at the same time positioning the bodies in the basin, with red fibre washer under the basin/sink.

Refer to **IMAGE 16** on page 15

5. Screw the basin flange on to the basin SBA - make sure clear washer (or o-ring on plaza models) are in the correct position. To adjust the height of the basin body loosen/tighten the back nut below the basin/sink (on the basin body).

6. Tighten the basin tee kinco nuts using a suitable spanner.

7. Attach Handles:

- Place the dress skirt and locking insert onto the spindle. (CS Tapware only)
- Place the insert onto the spindle.
- Using the slot in the anti vandal key push the circlip onto the circlip recess in the spindle.
- Push the handle onto the spindle spline and screw the locking insert into the handle. Use the key to tighten.
- Screw the dress skirt onto the locking insert and tighten up to the handle. (CS Tapware only)
- Repeat for other tap.

(Also Refer to handle fitment in Recess Adaptors section.)

7. Connect hot and cold supply lines to the appropriate basin/sink body.

8. Turn water on and check for leaks at all connection points, including the basin tee, spout and basin body. Tighten as required.

INSTALLATION OF NON REMOVABLE SCHOOL PATTERN BASIN SETS

As the handle is fixed to the spindle, the School Pattern Basin Set with Non Removable handles can only be fitted by removing the complete top assembly and fitting this separately as a complete unit.

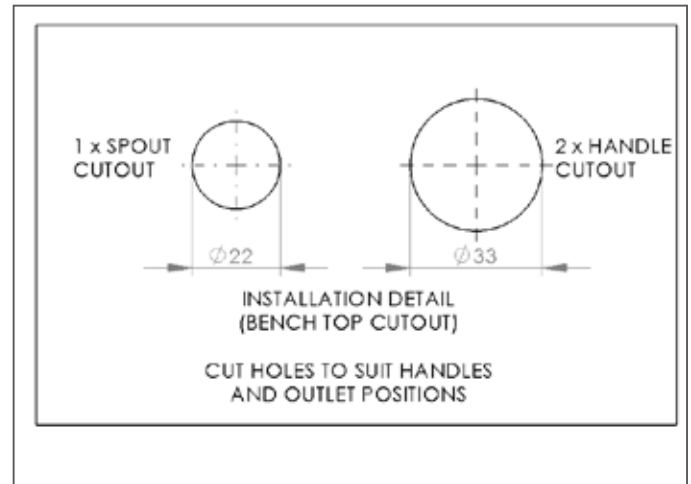

IMAGE 17 - Hole sizes if required

troubleshooting

Refer to the following trouble shooting guide for specific problems and solutions.

PROBLEM	CAUSE	RECITIFICATION
Taps are dripping water	Jumper valves are worn or damaged	Replace jumper valve
	Ceramic discs are worn or damaged from debris	Remove and inspect SBA. Remove debris and/or replace SBA if damaged.
	Tap seat is damaged	Refurbish tap seat using a reseating tool. If necessary – fit reseating kit.
Water is leaking from spindle	O-ring on spindle (jumper valve) is worn or damaged	Replace o-ring
Water is not flowing from tap	Water turned off	Turn water on
	Aerator or flow control is blocked by debris	Remove aerator and flow control from tap and clean debris. Install an inline strainer
Wall flange does not screw onto thread of SBA	Tap bodies are set too far into the wall	Use extended recess spindles or body extenders.
Wall flange does not screw down onto wall surface	Tap bodies are set too far out	Use a trouble dome or flange extender.
Spindle is difficult to turn (jumper valve)	Build up of scale on spindle, spindle worn or o-ring has been damaged	Jumper valve spindle needs to be removed, cleaned and regreased. O-ring to be replaced. Complete SBA may need to be replaced.
Handle is loose	Insert has come loose	Tighten insert with Anti Vandal key
	Circlip not fitted into the correct groove	Reposition circlip into the correct groove on the spindle

service and maintenance

JUMPER VALVE PRODUCTS (VP, IN & PZ Range)

1. Turn off the water supply and turn on the tap handle to drain water from the wall bodies
2. Remove the insert from the handle by using the spanner key, then remove the handle
3. Use the semi-circle cutout on the spanner key to push & remove the circlip from the spindle, then remove the insert from the spindle
4. Unscrew the flange from the stuffing box by hand
5. Use a spanner to remove the stuffing box assembly from the tap body
6. Unscrew and remove the spindle from the stuffing box
7. Check the o-ring on the spindle and the jumper valve for wear and damage. Replace them if required. For spare parts, please refer to relevant spare parts list
8. Clean the spindle and the stuffing box for debris and scales
9. Place a new o-ring (if required) onto the spindle and re-grease lightly
10. Reassemble the spindle into the stuffing box. Place a new fibre washer on the stuffing box seating face and reassemble the jumper valve
11. Follow the installation guide for the relevant product to reassemble the recess adaptor back onto the wall bodies

CERAMIC DISC PRODUCTS (VP, IN & PZ Range)

1. Turn off the water supply and turn on the tap handle to drain water from the wall bodies
2. Remove the insert from the handle by using the spanner key, then remove the handle
3. Use the semi-circle cutout on the spanner key to push & remove the circlip from the ceramic cartridge, then remove the insert from the spindle
4. Unscrew the flange from the locknut by hand
5. Use a spanner to remove the locknut assembly from the tap body
6. Unscrew and remove the ceramic cartridge from the locknut
7. Replace the cartridge and hand tighten back into the tap body.
8. Clean the locknut for debris and scales
10. Place a new fibre washer on the base of the locknut
11. Follow the installation guide in section 3 for the relevant product to reassemble the recess adaptor back onto the wall bodies

JUMPER VALVE PRODUCT (CS Range)

1. Turn off the water supply and turn on the tap handle to drain water from the tap bodies
2. Unscrew and remove the skirt from the insert by hand
3. Remove the insert from the handle by using the spanner key, then remove the handle
4. Use the semi-circle cutout on the spanner key to push & remove the circlip from the spindle, then remove the insert from the spindle
5. Unscrew the flange from the stuffing box by hand
6. Using a spanner remove the stuffing box assembly from the tap body
7. Unscrew and remove the spindle from the stuffing box
8. Check the o-ring on the spindle and the jumper valve for wear and damage. Replace them if required. For spare parts, please refer to relevant spare part list
9. Clean the spindle and the stuffing box for debris and scales
10. Place a new o-ring (if required) onto the spindle and re-grease lightly
11. Reassemble the spindle into the stuffing box. Place a new fibre washer on the stuffing box seating face and reassemble the jumper valve
12. Follow the installation guide for the relevant product to reassemble the recess adaptor back onto the wall bodies

CERAMIC DISC PRODUCT (CS Range)

1. Turn off the water supply and turn on the tap handle to drain water from the wall bodies
2. Unscrew and remove the skirt from the insert by hand
3. Remove the insert from the handle by using the spanner key, then remove the handle
4. Use the semi-circle cutout on the spanner key to push & remove the circlip from the ceramic cartridge, then remove the insert from the ceramic cartridge
5. Unscrew the flange from the locknut by hand
6. Use a spanner to remove the locknut assembly from the wall body
7. Unscrew and remove the ceramic cartridge from the locknut
8. Replace the cartridge and hand tighten back into the wall body.
9. Clean the locknut for debris and scales
10. Place a new fibre washer on the base of the locknut
11. Follow the installation guide in section 3 for the relevant product to reassemble the recess adaptor back onto the wall bodies

Enware Australia Pty Limited (ACN 003 988 314) (“we” or “us”) warrants that this product (also referred to as “our goods”) will be free from all defects in materials and workmanship for 24 months* from the date of purchase. Our liability under this warranty is limited at our option to the repair or replacement of the defective product or part, the cost of repair of the defective product or part or the supply of an equivalent product or part, in each case if we are satisfied the loss or damage was due to a defect in the materials or workmanship of the product or part. All products must be installed in accordance with the manufacturer’s instructions, the PCA, and AS/NZS3500 including any other applicable regulatory requirements.

making a claim

To make a claim under this warranty you must notify us in writing or via the online Online Product Service and Warranty Form* within 7 days of any alleged defect in the product coming to your attention. Proof of purchase of the product must also be supplied. All notifications and accompanying information must be sent marked for the attention of the Enware Australia Pty Limited,

9 Endeavour Road, Caringbah NSW 2229.

We can also be contacted by telephone on 1300 369 273 (AUS) or +61 2 8536 4000 or by email to info@enware.com.au

Your costs in making a claim under this warranty, including all freight, collection and delivery costs, are to be borne and paid by you. We also reserve the right at our cost to inspect any alleged defect in the product wherever it is located or installed or on our premises.

* www.enware.com.au/product-service-enquiry

Conditional warranty: Jumper Valve Tapware - 2 Years: 1 year parts and labour on the complete assembly then a further 1 year parts only warranty is applicable

Ceramic Disc Cartridge Tapware - 10 Years: 10 Year ceramic disc cartridges – parts only; 1 Year parts and labour on complete assembly

Outlets - 1 Year parts and labour on the complete assembly

exceptions

This warranty does not apply in respect of any damage or loss due to or arising from:

- a) Failure by you or any other person to follow any instructions for use (including instructions and directions relating to the handling, storage, installation, fitting, connection, adjustment or repair of the product) published or provided by us;
- b) Failure by you or any other person responsible for the fitting, installation or other work on the product to follow or conform to applicable laws, standards and codes (including the AS/NZ 3500 set of Standards, all applicable State and Territory Plumbing Codes, the Plumbing Code of Australia and directions and requirements of local and other statutory authorities); or
- c) Any act or circumstance beyond our control including faulty installation or connection, accident, abnormal use, acts of God, damage to buildings, other structures or infrastructure and loss or damage during product transit or transportation.

other conditions

Except as provided or referred to in this document, we accept no other or further liability for any damages or loss (including indirect, consequential or economic loss) and whether arising in contract, tort or otherwise. Any benefits available to you under this warranty are in addition to any non-excludable rights or remedies you may have under applicable legislation, including as a “consumer” under the Australian Consumer Law. To that extent you need to be aware that: Our goods come with guarantees that cannot be excluded under the Australian Consumer Law. You are entitled to a replacement or refund for a major failure and for compensation for any other reasonably foreseeable loss or damage. You are also entitled to have the goods repaired or replaced if the goods fail to be of acceptable quality and the failure does not amount to a major failure.



ADDRESS: 9 Endeavour Road, Caringbah NSW 2229 Australia

POSTAL ADDRESS: P.O. Box 2545, Taren Point NSW 2229 Australia

PHONE: 61 2 8536 4000 **FAX:** 61 2 8556 4066

1300 369 273 [AUS] WWW.ENWARE.COM.AU INFO@ENWARE.COM.AU

ABN 23 003 988 314

