

A

B

C

D

ITEM NO.	PART NUMBER	DESCRIPTION	QTY.
1	894245	INSERT - RUBBER GUARD BUBBLER	1
2	693213 POLYPROPYLENE COMPONENT		1
3	672630	SCREW - GRUB M5 X 6 S/S GRADE 304	1

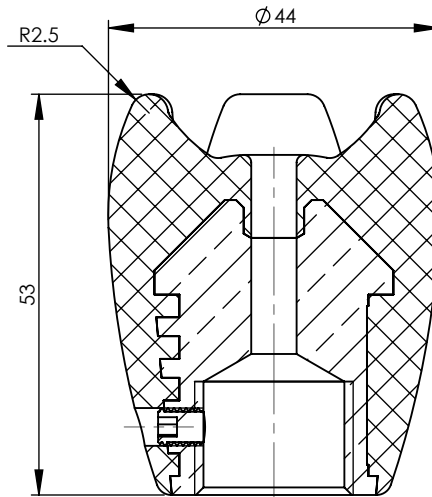
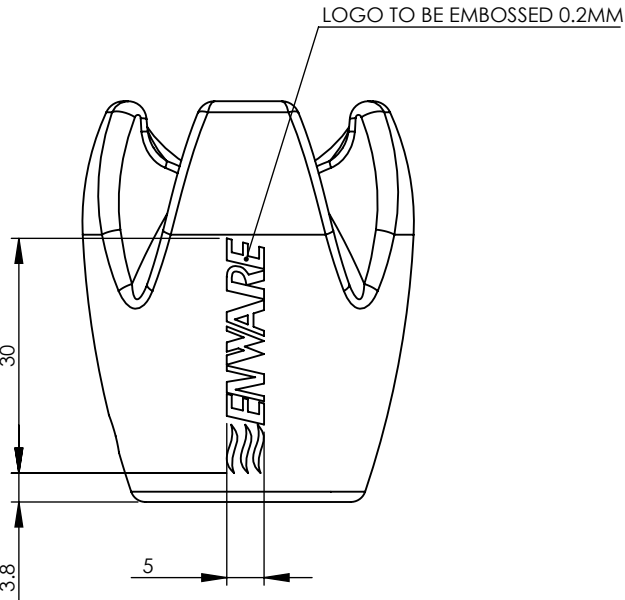
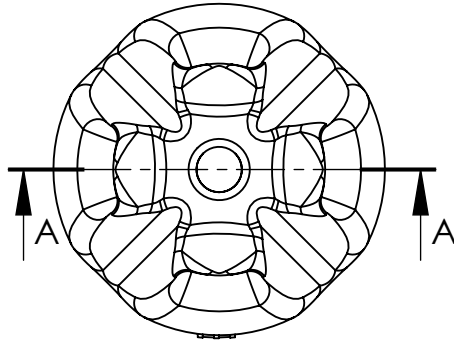

SECTION A-A

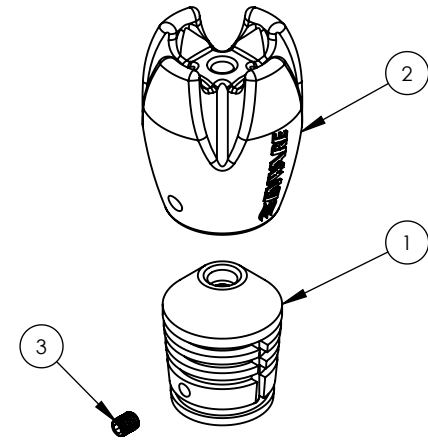

4

REVISION				
REV.	DATE	ECN	DESCRIPTION	MODIFIED BY
A	14/04/04		DRAWN IN CAD	
B	29/09/05		DRAWN IN SOLIDWORKS; MATERIAL ADDED	
C	8/02/10		NEW GUARD DESIGN, MATERIAL AND COLOUR	AC
D	7/07/15	4576	NEW INSERT DESIGN - 894245 UPDATED	YK

**GENERAL NOTES:**  
 - REMOVE ALL BURRS AND SHARP EDGES UNLESS OTHERWISE STATED  
 - ALL THREADS TO BE CHAMFERED  
 - DIMENSIONS ARE IN mm's  
 - DO NOT SCALE OFF DIMENSIONS

**TOLERANCE EXCEPT WHERE STATED:**  
 NO DECIMAL POINT    √ 0.2  
 ONE DECIMAL PLACE    √ 0.1  
 TWO DECIMAL PLACES    √ 0.05  
 ANGLES                    √ 1°

DRAWN	YK
CHECKED	CL
APPROVED	LR

This drawing is the property of Enware Australia Pty Ltd and may not be reproduced in full or part without the written consent of Enware Australia.



9 Endeavour Rd,  
 Caringbah, NSW, 2229  
 Ph. 61-2-9525-9511  
 Fax. 61-2-9524-8421

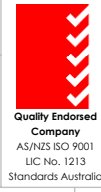

<b>TITLE</b> <b>GUARD-BUBBLER RUBBER</b>	
MATERIAL: SEBLEX 7848	DRAWING NUMBER <b>693213</b>
FINISH: BLUE	
SIZE: A4	SCALE: 1:1
	SHEET: 1 OF 1

A

B

C

D