

ITEM NO.	PART NUMBER	DESCRIPTION	QTY.
1	880221	HANDLE & INSERT-LAB	1
2	672120	CIRCLIP-SPINDLE BRS	1
3	880505	SPANNER-VANDAL PROOF	1
4	672090	BUTTON COLD	1

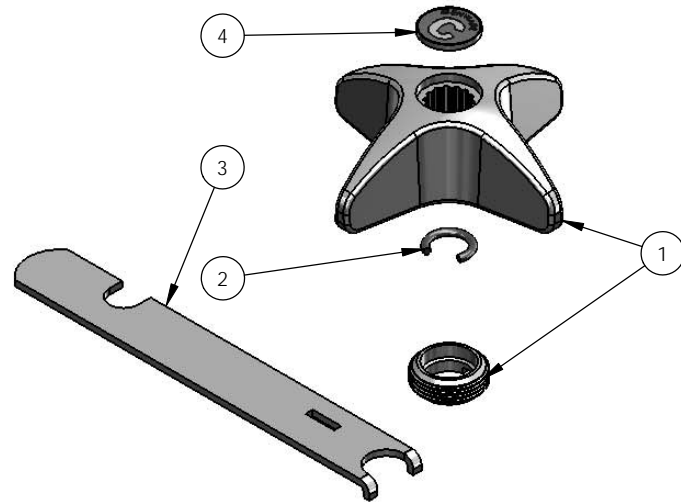
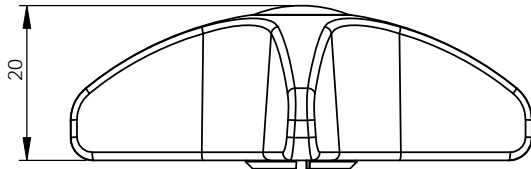
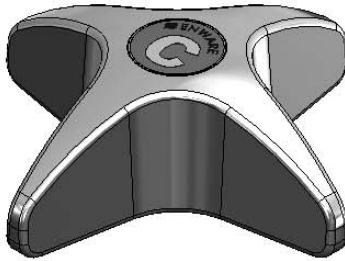
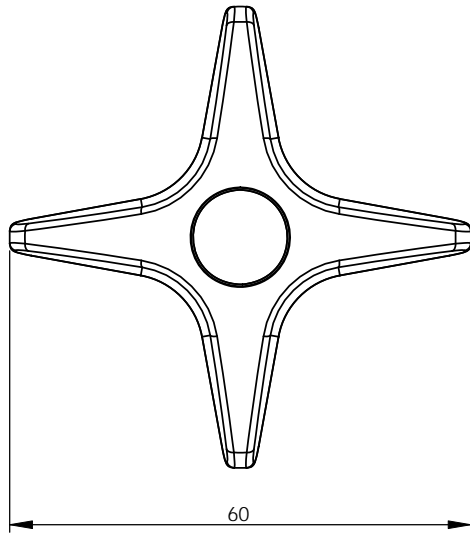

REV	DATE	CN	AMMENDMENTS	MODIFIED BY
A	14/03/06		FIRST ISSUE	
B	07/01/08		REDRAWN	

GENERAL NOTES:
 REMOVE ALL BURRS AND SHARP EDGES UNLESS OTHERWISE STATED
 DIMENSIONS ARE IN mm's

TOLERANCE EXCEPT WHERE STATED:

NO DECIMAL POINT / 0.2
 ONE DECIMAL PLACE / 0.1
 TWO DECIMAL PLACES / 0.05
 ANGLES / 1

ENWARE RESERVES THE RIGHT TO AMEND PRODUCT SPECIFICATIONS AND DESIGNS WITHOUT NOTICE.

DRAWN	SM	9 Endeavour Rd, Caringbah, NSW, 2229 Ph. 61-2-9525-9511 Fax. 61-2-9524-8421	
CHECKED			
APPROVED			
TITLE: VP HANDLE			
Scale: Not To Scale		Scale: Not To Scale	
MATERIAL:			
FINISH: CHROME PLATED			
This drawing is the Copyright of Enware Australia Pty Ltd and may not be reproduced in full or part without the written consent of Enware Australia Pty Ltd		DWG NO.	SHEET 1 OF 1
		VP378	