

TOUCH-ACTIVATED DUAL FLUSH WC STANDARD FLUSHING SYSTEM - DUCT ACCESS

Installation & Maintenance Instructions

EMF410M

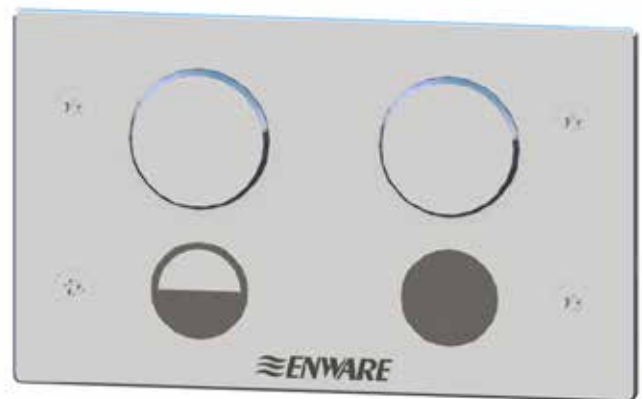

I00003_Aug 13

Call 1300 369 273
www.enware.com

Enware Australia Pty Limited
9 Endeavour Rd Caringbah NSW 2229 Australia
Ph: 02 8536 4000 Fax: 02 8556 4055

installingconfidence

Touch-Activated Dual Flush WC Standard Flushing System - Duct Access

Enware's WC flushing systems provide a neat and reliable flushing solution using piezoelectric technology particularly suited for public access applications.

Uses a WaterMarked solenoid that when combined with an appropriate pan delivers either a 3/6L or 3/4.5L flush.

Best suited for duct style installation (Flush unit and activation plate **MUST** be separated.) Stylish and strong electronic piezo operation using mains power.

Semi concealed installation with a stainless steel panel and security screws. Shut off valve, filter and airbreak included.

EMF410M

FEATURES

- Piezo touch button control
- 3 or 4 Star water efficiency rating
- Mains power 24V
- Compact face plate
- Vandal resistant torx screws
- ATS5200.020
- 1-year warranty

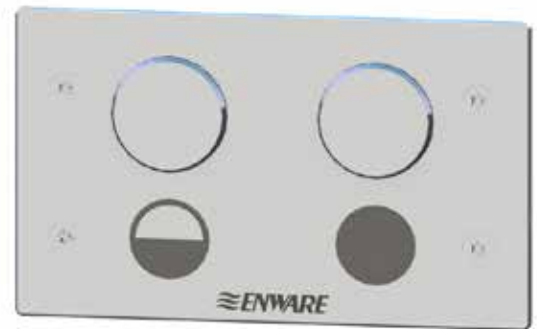

Product Codes

- EMF410M-3** WELS 3 Star rated*
- EMF410M-4** WELS 4 Star rated*

Technical Information

Water Supply	300 kPa
Connection	Inlet - 1" BSP (25mm)
	Outlet - 1 1/2" BSP (40mm)
Minimum Water Supply Line Size	1" (25mm) copper pipe
Mains Powered	24V AC transformer
Kv Factor	8.3m ³ /h
Flush Pipe	1 1/2" (40mm) flush pipe is required below the air break. (Note: use a maximum of 1x90° bend in flush pipe. If an offset is required 2 x 45° bends must be used. Maximum of 1 offset per flush pipe. Air break must be installed in a vertical position at 700mm +/- 100 mm above the pan inlet.
Pan	6/3L Capacity (3 star)
	4.5/3L Capacity (4 star)

Enware tapware must be installed in accordance with the provisions of AS/NZS3500 and any relevant local regulations. Installations not complying with AS/NZS3500 may void the product and performance warranty provisions. As Enware's product development is ongoing, product specifications may vary over time.

* WELS volume is only achieved at 300kPa. Use a pressure limiting valve to achieve

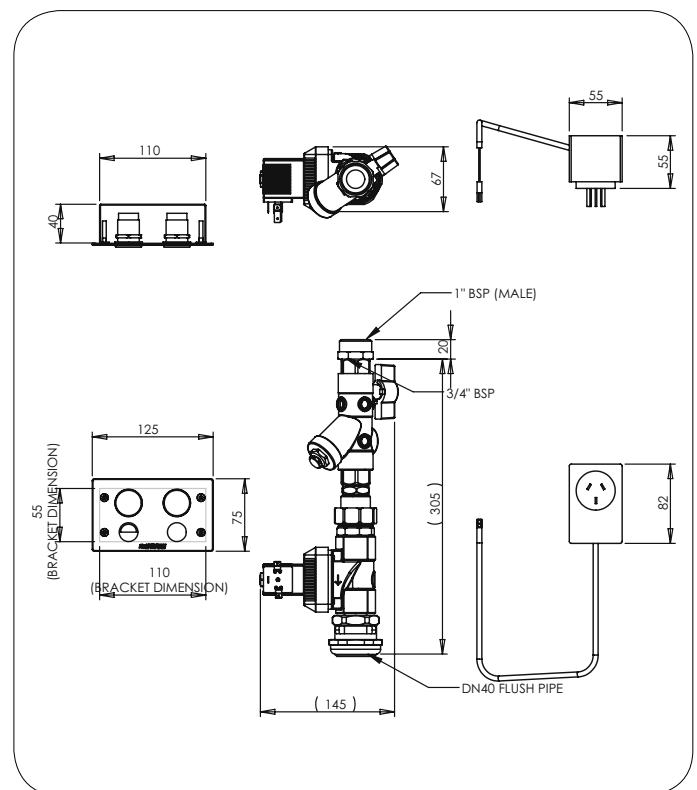

Version: Aug 13

Call 1300 369 273
www.enware.com

Enware Australia Pty Limited
9 Endeavour Rd Caringbah NSW 2229 Australia
Ph: 02 8536 4000 Fax: 02 8556 4055

ENWARE
installing confidence

INSTALLATION INSTRUCTIONS

Before proceeding with installation ensure all operating & dimensional specifications are suitable for the intended installation.

IMPORTANT TECHNICAL REQUIREMENTS

To ensure that the unit works correctly, it is important to ensure that the site and location of installation meets the hydraulic requirements of AS/NZS 3500.1. Also there must be:

- Minimum 25mm copper supply line
- Minimum 200kPa for valve to operate.
NOTE: WELS Volume only achieved at 300kPa
- 40mm flush pipe must be used (PVC adaptors to be supplied by the client if required) (See FIGURE 1.1)
- Only 1 x 90° bend in flush pipe (any other bends are required to be 45° - maximum of 2)
- Air break must be installed in a vertical position.

Pipe work to the valve fixture must be sized according to water service rule calculations and simultaneous demand requirements. To ensure that the pipeline reticulation system for the valve is designed correctly for the satisfactory performance of the valve a Hydraulic services Consultant and/or Engineer (or other personnel appropriately qualified in hydraulic services design) must be engaged.

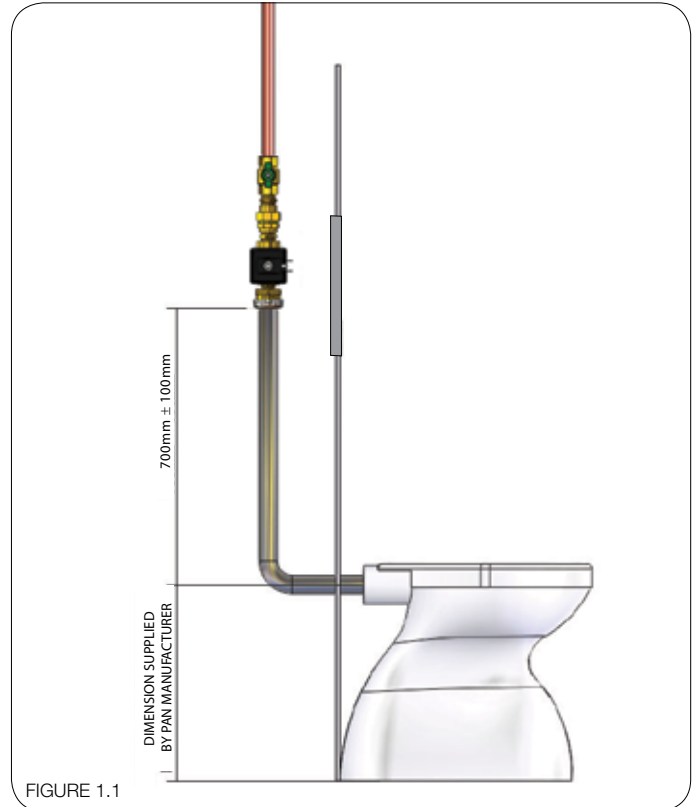

FIGURE 1.1

1.2 INSTALLATION INSTRUCTIONS

1. Separate all parts from packaging & check each part with contents section (refer Fig 2.1). Pay attention to the different models variations. Make sure all parts are accounted for before discarding any packaging material. If any parts are missing, do not attempt to install your flushing system until missing parts are obtained.
2. Flush water supply lines thoroughly before installing the flush valve. Do not allow dirt, thread sealant or metal particles enter the unit.
3. Fit the flush valve in the required position (take note of installation guidelines). If using PVC flush pipe, a 40mm cap and lining must be fitted to the air break. (cap and lining not supplied)
4. Fix noggins in the correct position for fascia plate bracket mounting.
5. Run conduit from solenoid valve to power supply and thread transformer wire through (2m extension lead available from Enware part No. EMDS801)
6. Turn water supply on and check for leaks. (note Ball Valve still in off position.)

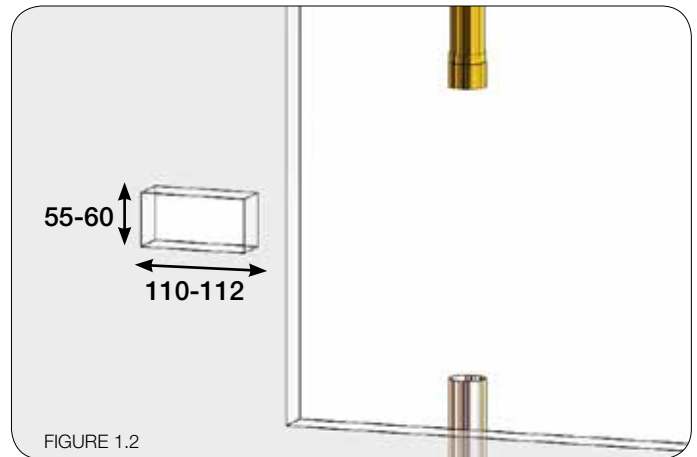

FIGURE 1.2

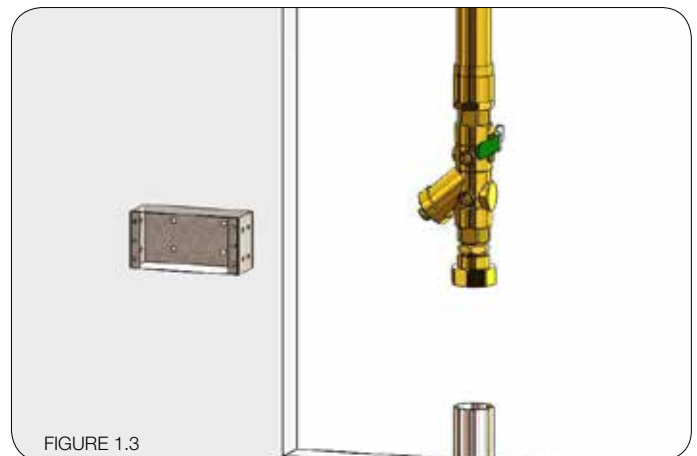

FIGURE 1.3

INSTALLATION INSTRUCTIONS

7. Turn inlet ball valve on and check for leaks (make sure the solenoid is not connected to power)
8. When the wall is fitted, allow 55mmx110mm cut out for fascia plate fixing. (Figure 1.2) Note: Ideal button height is approximately 700mm from top of pan.
9. Fit the piezo button to the stainless steel cover plate. Ensure red fibre washer is used. Take note of the half flush tag and full flush tag at the back of the piezo. (FIGURE 1.5)
10. Piezo cable connection
Locate the positive wire from each piezo (indicated by the black strip on the wire). Plug both positive spade connectors into one side of the solenoid. Locate the two remaining negative wires and plug into the other side of the solenoid. (FIGURE 1.6)
11. Connect power
Plug the transformer lead in to the female socket connection on the Full Flush button cable. This will leave one male connector on the Full Flush cable. Plug this male connector in to the female connector on the Half Flush button cable. (2m extension available if required - EMDS801) (FIGURE 1.7)
12. Fit mounting bracket with in wall cavity.
13. Fit stainless steel face plate with piezo to the mounting bracket in wall (FIGURE 1.8)
14. Turn on shut off valve and transformer. Test system.

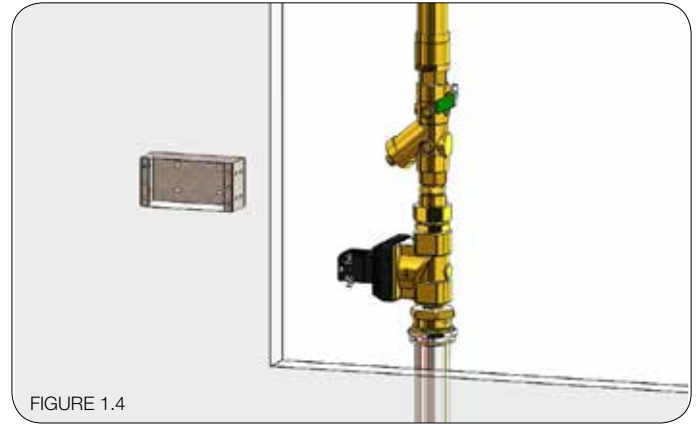

FIGURE 1.4

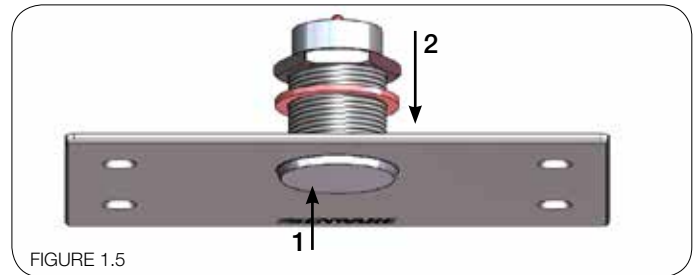

FIGURE 1.5

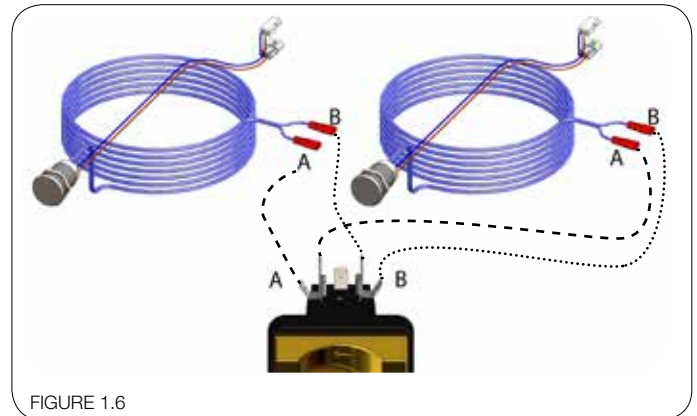

FIGURE 1.6

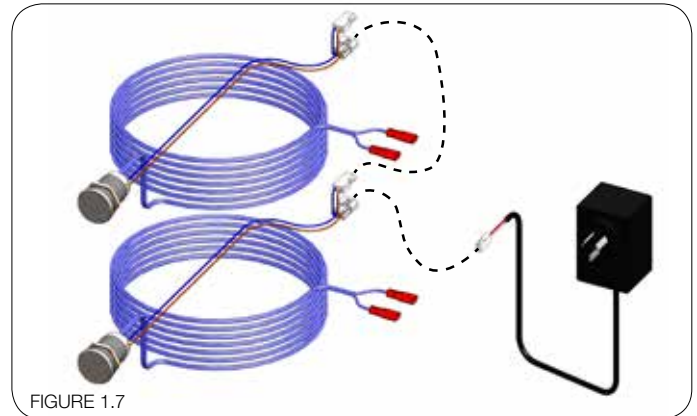

FIGURE 1.7

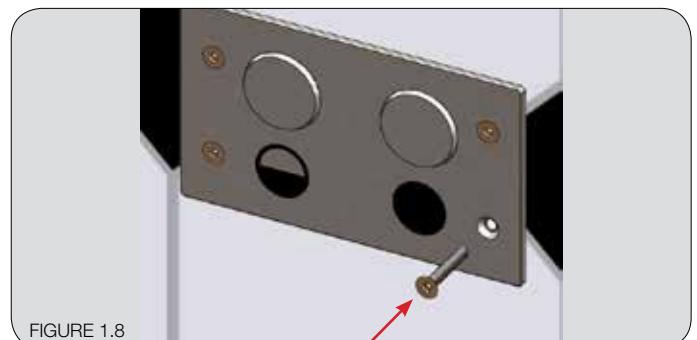
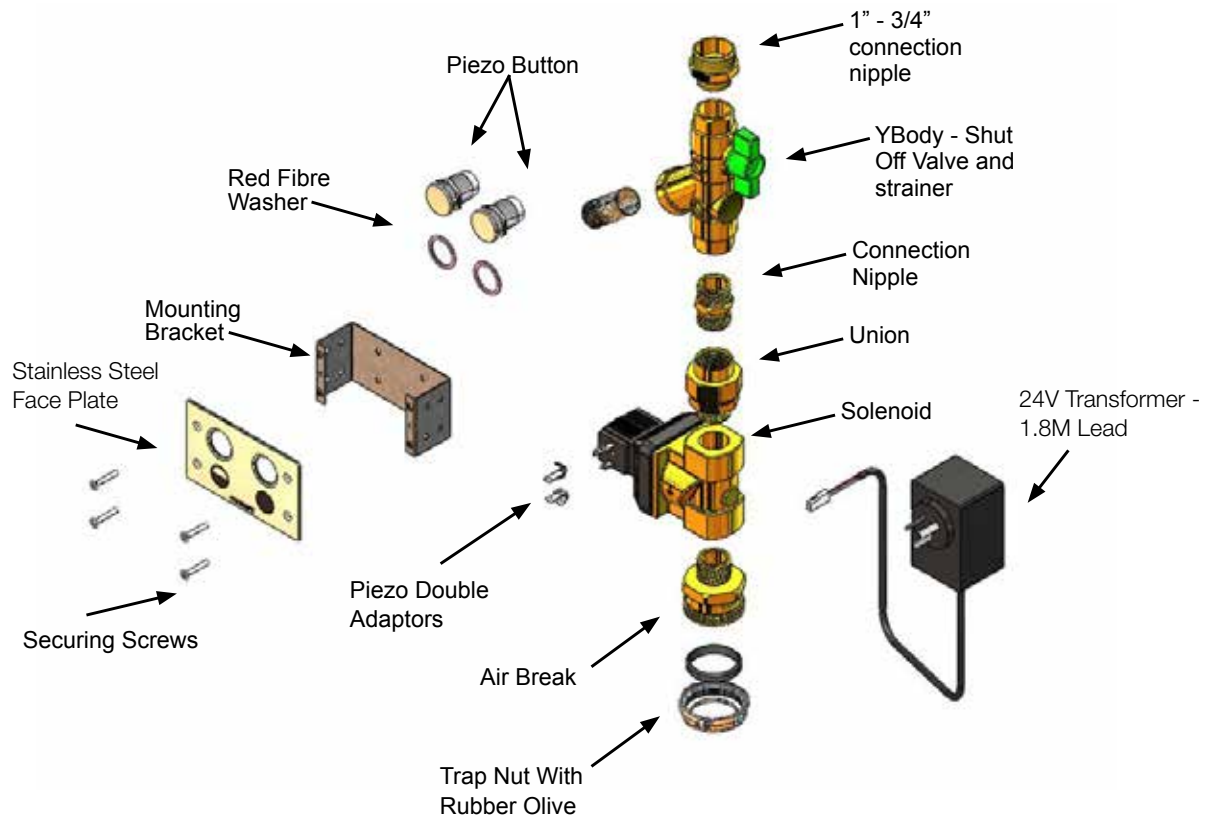

FIGURE 1.8

PRODUCT COMPONENTS AND SPARE PARTS LIST

2.1 EXPLODED VIEW



2.2 SPARE PARTS

EMDS800	24V Transformer - 1.8M Lead
EMFS301	Swith Piezo 22mm Fixed Half Flush
EMFS302	Swith Piezo 22mm Fixed Full Flush
EMFS303	Solenoid 3/4 24V AC
EMFS307	Spade Connector Piezo Dual Flush
EMFS306	Rubber Olive
EMFS305	Y Body - Shut off valve and strainer
EMFS308	Strainer filter replacement

2.3 OPTIONAL PART

EMDS801	2m Power to piezo extension lead
---------	----------------------------------

SERVICE AND MAINTENANCE

3.1 FILTER CLEANING

This flush valve is provided with a stainless steel filter preventing foreign particles from entering the lines. If the water flow has decreased, this may be because the filter is clogged. They can be cleaned as follows:

1. Turn-off the water shut off valve
2. Open the filter cap on the Y body, directly below shut off valve
3. Remove the filter and wash it under running water. It may be necessary to replace the filter (spare parts can be ordered from Enware)
4. Reinsert the filter and refit the filter cap
6. Turn on the water shut off valve
7. Make sure that there is no leakage

3.2 SERVICE INSTRUCTIONS

Refer to trouble shooting chart to help determine specific problems.

Complete service instructions are supplied with each spare part kit and these should always be referred to before disassembling any fitting. Spare part kits should be on hand before any complete service of the tap is undertaken.

SERVICE AND MAINTENANCE

3.3 TROUBLE SHOOTING

Refer to the following trouble shooting chart for specific problems and solutions. Service instructions are supplied with spare part kits

PROBLEM	CAUSE	RECTIFICATION
Button pressed - water does not flow	Loose connection on leads	Reconnect electrical connections
	Piezo switch is not working	Piezo switch or transformer faulty
	Dirty Filter	Refer to 3.1 Filter Cleaning on page 6.
	Supply pressure issue	Ensure pressure delivered to unit is above 200kpa and below 500kPa (dynamic)
Water does not stop flowing	Debris or scale in the solenoid	Remove solenoid, pull out plunger and spring & clean them. Use scale remover if required. When replacing plunger, ensure spring is in vertical position
	Dirty Filter	Refer to 3.1 Filter Cleaning on page 6.
	Supply pressure issue	Ensure pressure delivered to unit is above 200kpa and below 500kPa (dynamic)
Flush pattern not fully covering bowl	Supply pressure issue	Ensure pressure delivered to unit is above 200kpa and below 500kPa (dynamic)
	Supply pipe inadequate size	Ensure supply is 25mm (minimum)
	Pan water requirements not met by flushing mechanism	Refer to pan manufacturers instructions. If pan is 6/3L style, look at supply pressure issues. Otherwise replace pans with 6/3L style
Too little water delivered	Supply pressure issue	Ensure pressure delivered to unit is above 200kpa and below 500kPa (dynamic)
	Supply pipe inadequate size	Ensure supply is 25mm (minimum)
	Pan water requirements not met by flushing mechanism	Refer to pan manufacturers instructions. If pan is 6/3L style, look at supply pressure issues. Otherwise replace pans with 6/3L style



installing**confidence**

ADDRESS: 9 Endeavour Road, Caringbah NSW 2229 Australia

POSTAL ADDRESS: P.O. Box 2545, Taren Point NSW 2229 Australia

PHONE: 61 2 8536 4000 **FAX:** 61 2 8556 4066

1300 369 273 (AUS) WWW.ENWARE.COM.AU INFO@ENWARE.COM.AU

