

A

B

C

D

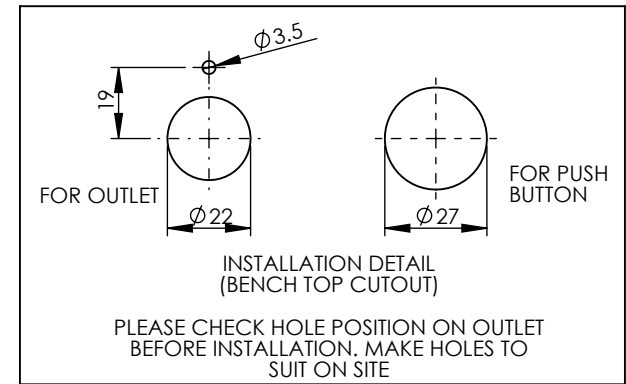
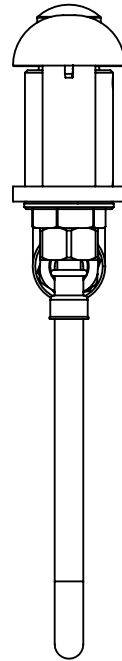
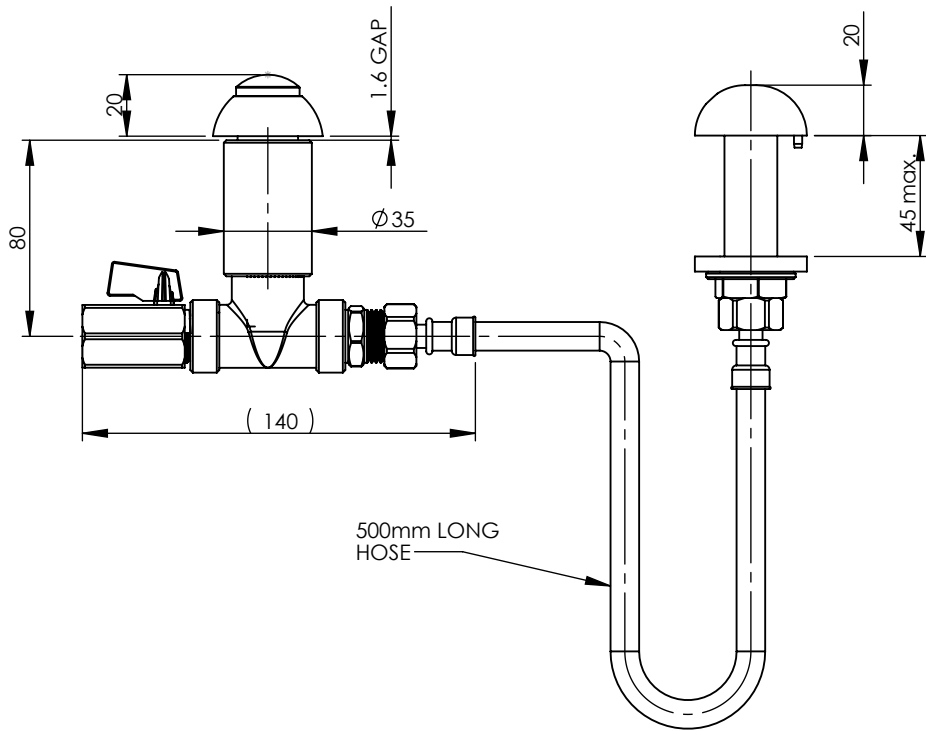
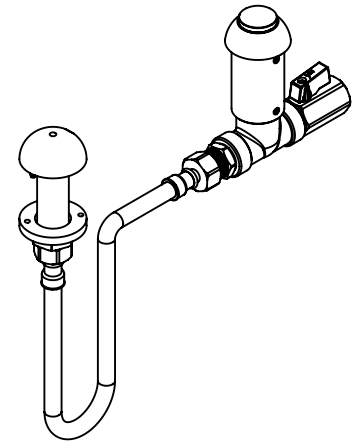
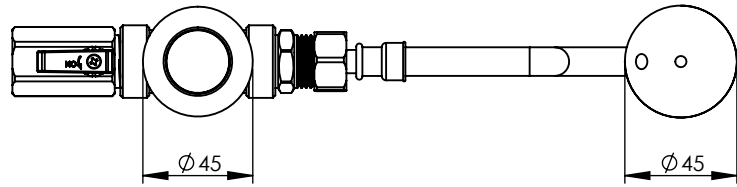

GENERAL NOTES:
 - DIMENSIONS ARE IN mm's
 - DO NOT SCALE OFF DIMENSIONS
 - TAPWARE TOLERANCE / 2 (EXCEPT WHERE STATED)
 - SAFETY SANITARY AND CARE TOLERANCE / 5 (EXCEPT WHERE STATED)

This drawing is the property of Enware Australia Pty Ltd and may not be reproduced in full or part without the written consent of Enware Australia.

DRAWN	AM
CHECKED	TD
APPROVED	TD



9 Endeavour Rd,
 Caringbah, NSW, 2229
 Ph. +61 2 8536 4000
 Email: info@enware.com.au

DRAWING NUMBER: DET685	REV: D.0
DESCRIPTION: CELL BSN P/BUTTON & BSN ASSY STD CP	
FINISH: CHROME PLATED	SIZE: A4 SCALE: 1:3

A

B

C

D