

#PA BC "	D5FHBI A 69F	89G7 F-DHC B	E HM
%	., '\$')%	C I H9H6C 8M89H*%+	%
&	*+&\$)%	657? BI H%&: @B: 98 6FG@5F: 9	%
(	*+')+-	GD57 9F 89H6F5GG: C F C I H9H6G	%
)	*+& , %	K 5J 9DB* A A L %&A A G#G	%
*	*+&( (&	F9 !: @K 7 C B H C @9F A F \$%5: J = D#7 C 7?	%
	+ - &) *	J 5 @ 9 A - B = 65 @ < 5 @ - B 7 < A :	%

⑦ BC H9.

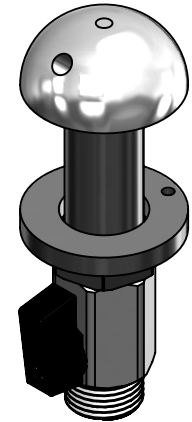

8C BC HI G9K #k 'H 9FA 5@A ± B; J 5@ 9 fHA J Ł ÷ HA J 'G'F9E I F 98 ŽI G9 89H\* %

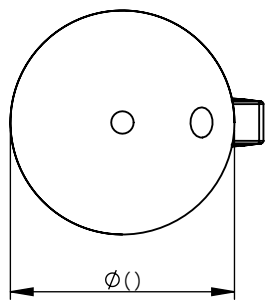
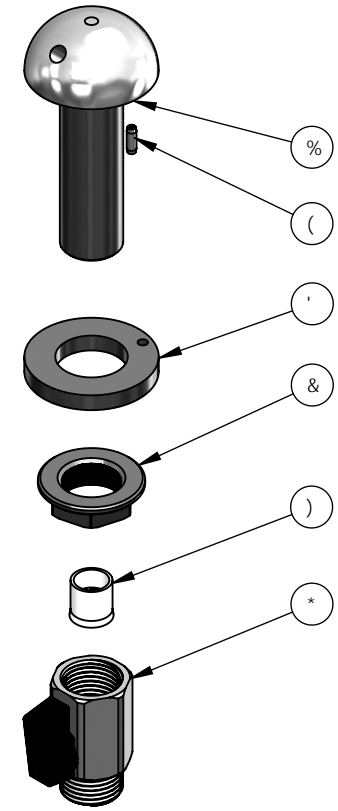
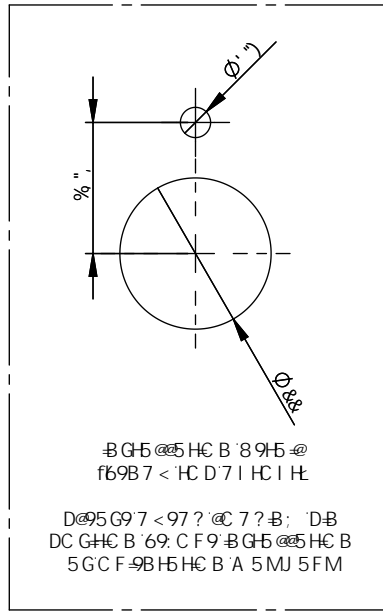
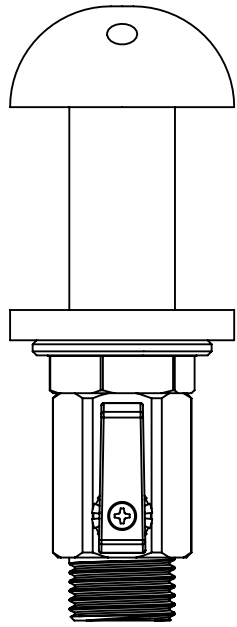
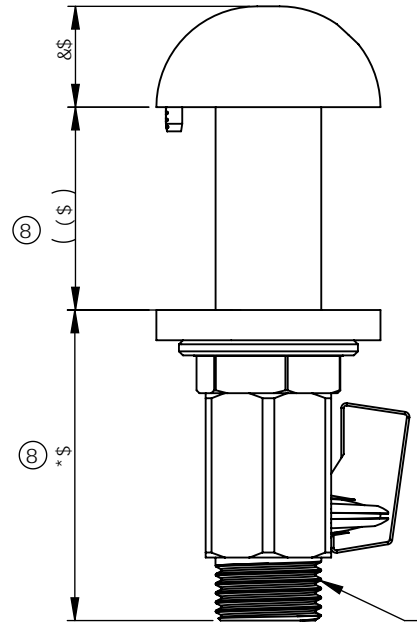

F9J	85H9	7B	5A A 9B8A 9BHG	A C 8 ÷ 98 6M	9B 9F5@BCHG F9A C J 95 @ 61 FFG5B8 G-5FD 98: 9G I B @ 9G C H: 9FK @9 GH5H98 8 A 9BGC BG5F9-B a a 9 H C @ F 5 B 7 9 9 L 7 9 D H K < 9 F 9 G 5 H 9 8 . BC 897 A 5 @ DC BH ..... 1/2 \$%& C B 9 8 9 7 A 5 @ D @ 5 7 9 ..... 1/2 \$%& H K C 897 A 5 @ D @ 5 7 9 G ..... 1/2 \$%& 5B: @ 9G ..... 1/2 %	8F5K B ?B 7 < 97 98 5DDFC J 98 HH9: 89 H C B 6 6 6 @ F C I H 9 H 7 C @ 8 C B @ M GW.Y. BchH: GW.Y A 5H9F 5@ : B G<: 7 < F C A 9 D @ 5 H 9 B H J G X H K b l g h Y 7 c d m j \ h c z 9 b k U Y 5 i g r u j U D m e x U b x a U m b c h V Y f r d f c X i W X j z a c f d U h k h i c i h h Y k f h Y b V e b g h c h z 9 b k U Y 5 i g r u j U D m e x	- 9bXYUj ci fFXZ 7 U f j b [ V U \ Z B G K Z &&&- D \ " * 9 8 & - ) & ) 1 - ) % % : U I " * 9 8 & - ) & ( , ( & %	ENWARE AUSTRALIA PTY LIMITED 89H* %
5	%&#%&#*\$		: FGHGGI 9					
6	&&#%&#%\$		D#B: *+&( (&58898 ⑥	?B				
7	' \$#\$' #-\$		+ - &) *) '58898 Z B C H 9 58898 ⑦	GA				
8	' %\$%&#%&		*+') - K 5G* +&( +' Z f ( \$ k 5Gf() ) Ł * \$ K 5G + \$ ⑧	GA				