

#DA BC "	D5FHBI A 69F	8 9G7 F-DHC B	E HM
%	, (\$\$-	6C K @G'K K 5@@5B8 D98 9GH5 @	%

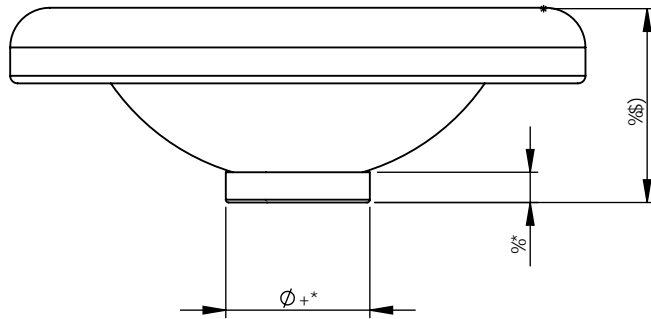
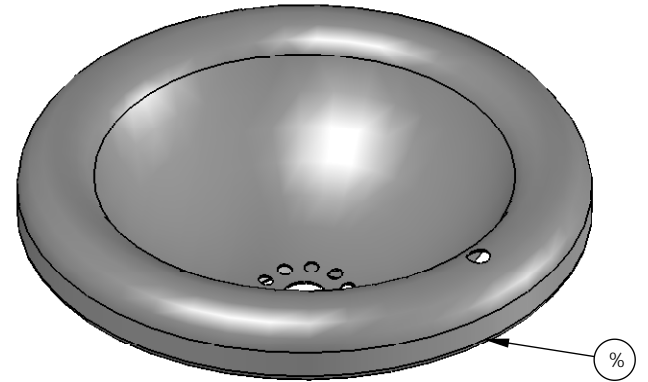
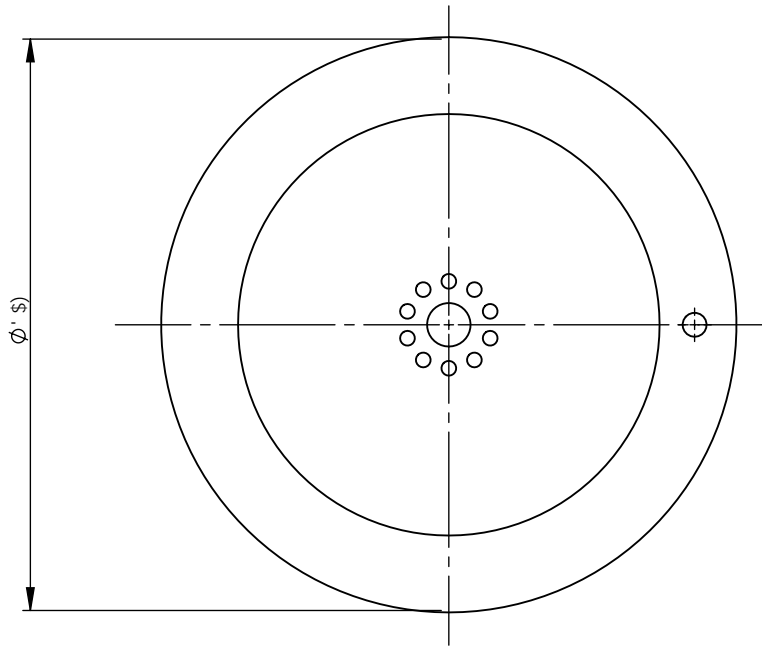

F9J	85H9	7 B	5A A 9B8A 9BHG	5 DD
5	%@#%\$#\$*		: #GH:GG 9	

: 9B 9F5@BCH9G  
 : F9A C J 95@@6l FFG5B8  
 : G-5FD 98: 9G1 B@9GG  
 : C H: 9FK @9 GH5H98  
 : 8 A 9B GC BG5F9-B a a fū  
 HC @F5B7 99L7 9DHK <9F9GH5H98:  
 BC 897 A 5@DC -BH"..... / \$"&  
 C B9897 A 5@D@57 9..... / \$%  
 HK C 897 A 5@D@57 9G..... / \$\*\$  
 5B: @G..... / %  
 9BK 5F9F99FJ 9GH: 9F@ <HHC 5A 9B8 DFC B1 7  
 Q97 @ 7 5HC BG5B8 89G@ BGK #C1 HBC H7 9

8F5K B	? B	- 9bXYUj ci fFXZ
7 <97 798	PK	7 Ufjpb[ VU\ZBGK Z&&&- D\ ""*%& -) & -) %%
5DDFC J 98		: UI ""*%& -) &( , (&%

HH@: G'G6C K @C B@M  
 GWUY .BchH: GWUY  
 A 5H9F 5@  
 : B G<.  
 H jgXfUk bl jghY 7 cdfj\ \hcZ  
 9bk UY 5i gfu jU Dtm@X UbX a Um  
 bc hVY fYdfCXi WX jz z cfdUth  
 k hci hAY k fHY b Vebg/bhcZ  
 9bk UY 5i gfu jU Dtm@X



8K : BC "  
 G< 99H%C : %  
**61 6&&+**