

#9A BC"	D5FHBI A 69F	89G7 F-DHC B	E HM
%	., \$%(-	8CA 9I7 5A FBI 66@9FL	%
&	*+&()	G7 F9K GC 7"; FI 6%BI&(1 B7 L' #%" GIG' \$(%

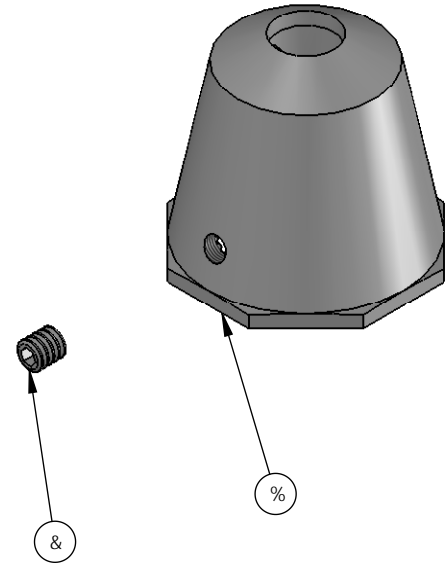
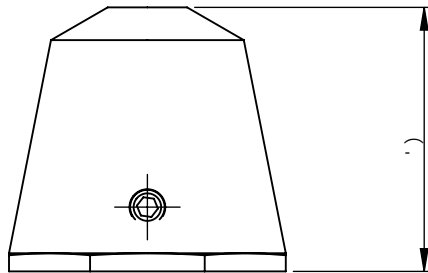
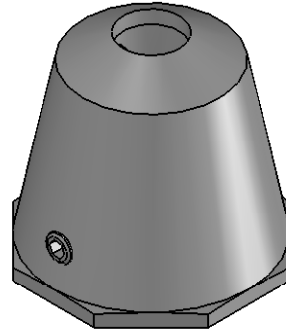
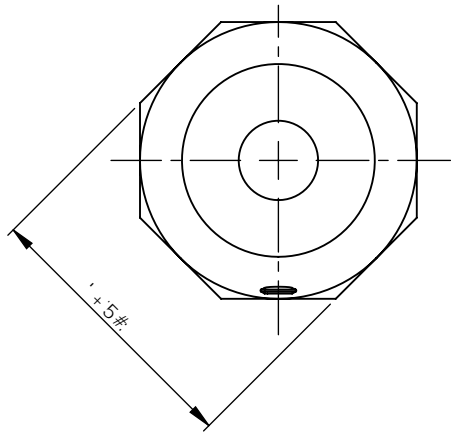

F9J	85H9	7 B	5A A 9B8A 9BHG	5 DD
5	%\$#%\$#\$*		: FGHGGI 9	

: 9B9F5@BCH9G
 : F9A CJ95@6l FFG5B8
 : G-5FD98: 9GI B@GG
 : C H:9FK 49 GH5H98
 : 8 A 9BGC BG5F9-B a a f
 HC @F5B799L7 9DHK <9F9GH5H98:
 BC 897 A 5@DC BH"..... 2/ \$"&
 CB9897 A 5@D@579..... 2/ \$%
 HK C 897 A 5@D@579G..... 2/ \$)\$
 5B: @G..... 2/ %
 9BK 5F9F99FJ 9GH:9F@ <HC 5A 9B8 DFC 8I 7M
 Q97 @ 75HC BG5B8 89G@ BGK #C I HBC H7 9

8F5K B	?B	- 9bXYUj ci fFXZ	
7 <97 798	PK	7 Ufj b[VU\ZBGK Z&&&- D\ "" *9&l-) &()L-) %& : UI "" *9&l-) &(!, (&%	
5DDFC J 98			
HH@: 6l 66@9F 8CA 97 5A 57 HC B			
GWUY .BchH: GWUY		GWUY .BchH: GWUY	
A 5H9F 5@			
: B G<.			
HjgXfUk bl jghY 7 cdfj\ \hcZ 9bk UY 5i gfu jU Dtm@X UbX a Um bc hVY fdfcXl WwX jz z cfdUth k fhci hAY k fhw b Vebg/bhcZ 9bk UY 5i gfu jU Dtm@X		8K : BC "	
6l 6&&%7		G< 99H%C : %	