

A

B

C

D

1

1

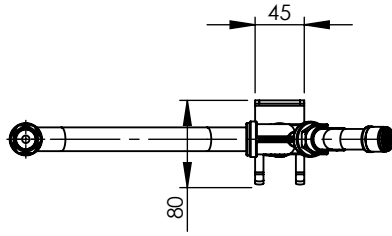

2

2

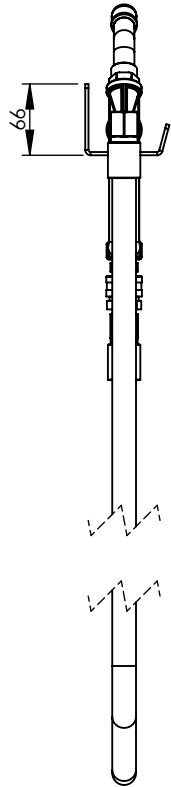

3 m LONG HOSE

3

3

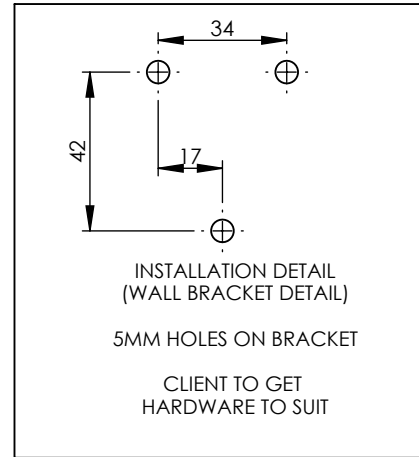
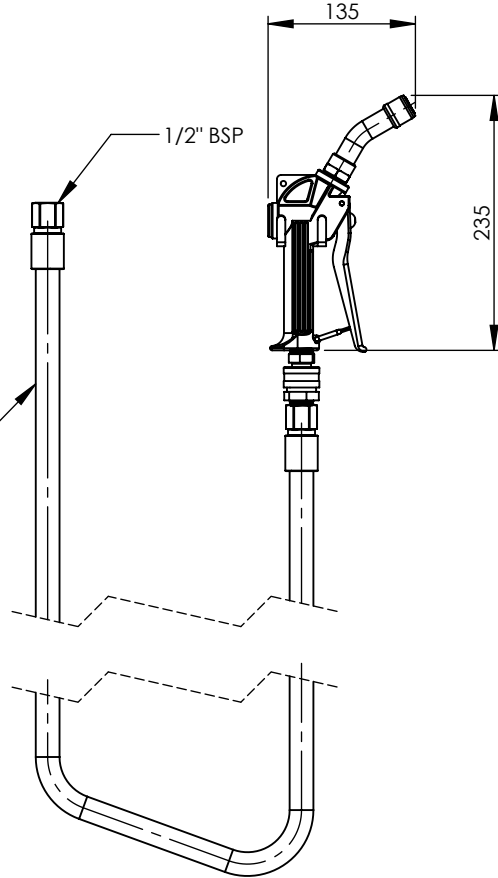

4

4

NOTES:-

1. MAXIMUM TEMPERATURE: 50 °C



GENERAL NOTES:

- DIMENSIONS ARE IN mm's
- DO NOT SCALE OFF DIMENSIONS
- TAPWARE TOLERANCE / 2 (EXCEPT WHERE STATED)
- SAFETY SANITARY AND CARE TOLERANCE / 5 (EXCEPT WHERE STATED)

This drawing is the property of Enware Australia Pty Ltd and may not be reproduced in full or part without the written consent of Enware Australia.

DRAWN	KN
CHECKED	RA
APPROVED	AK



9 Endeavour Rd, Caringbah, NSW, 2229 Ph. +61 2 8536 4000 Email: info@enware.com.au

DRAWING NUMBER: FWS830D	REV: F.0
DESCRIPTION: HAND/H TRIG SPRAY WITH 3M HOSE	
FINISH:	SIZE: A4 SCALE: 1:7

A

B

C

D