

A

B

C

D

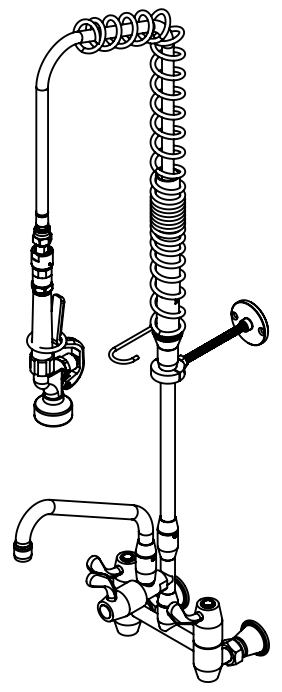
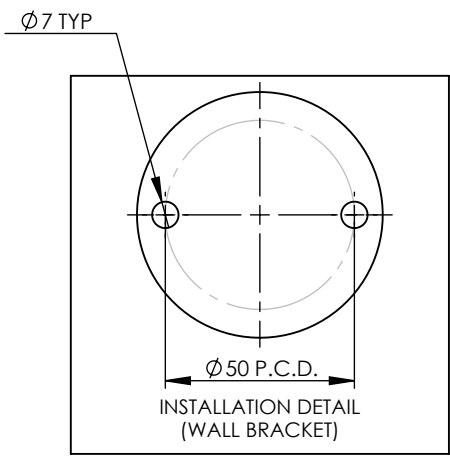
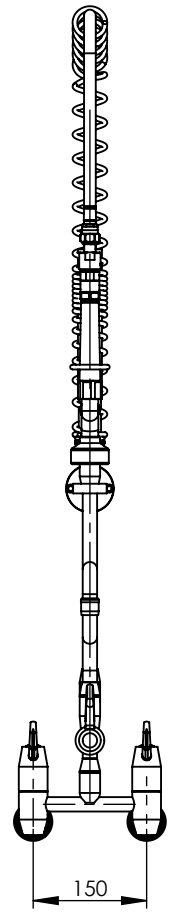
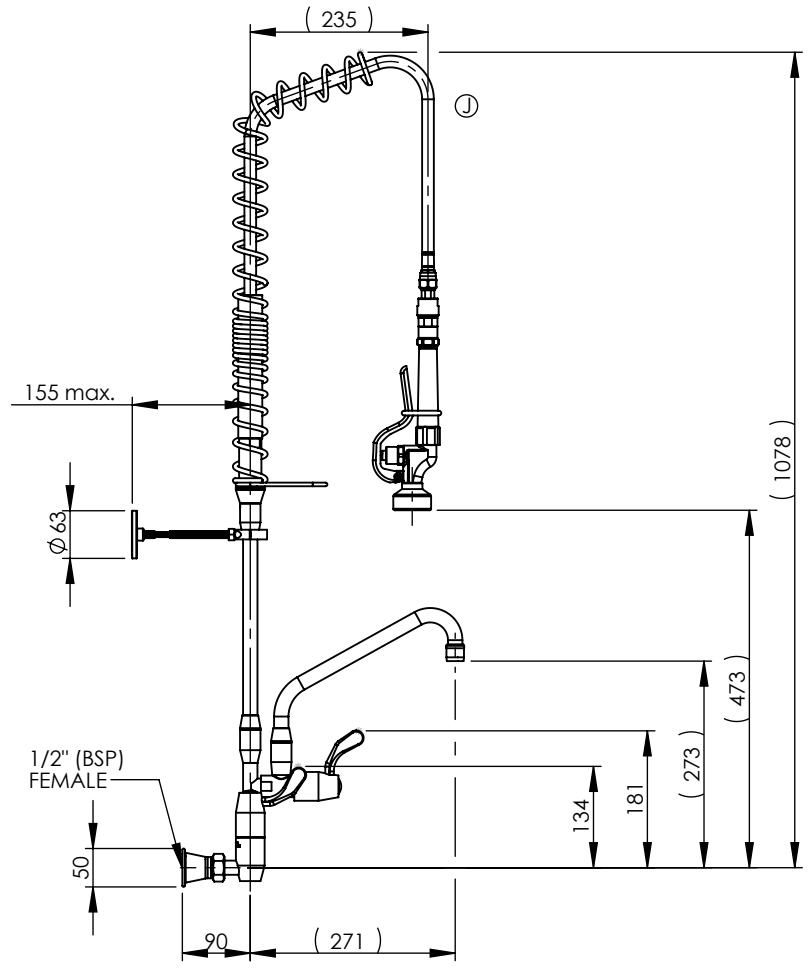
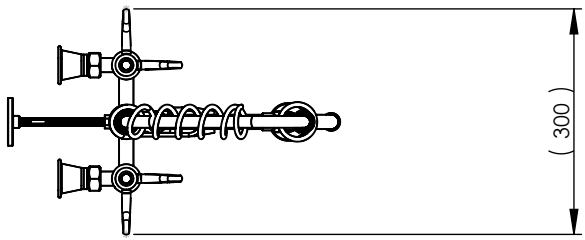

- NOTES:**
1. SPRAY GUN POSITION DIMENSIONS ARE APPROXIMATE AND REPRESENT A BRAND NEW UNIT.
  2. SPRING WILL SAG WITH USE OVER TIME.



**GENERAL NOTES:**  
 - DIMENSIONS ARE IN mm's  
 - DO NOT SCALE OFF DIMENSIONS  
 - TAPWARE TOLERANCE / 2 (EXCEPT WHERE STATED )  
 - SAFETY SANITARY AND CARE TOLERANCE / 5 (EXCEPT WHERE STATED )

This drawing is the property of Enware Australia Pty Ltd and may not be reproduced in full or part without the written consent of Enware Australia.

DRAWN	PK
CHECKED	CL
APPROVED	LR



DRAWING NUMBER	FWS131	REV	J.0
DESCRIPTION	PR WALL EXP/MIX W/POT FILLER	FINISH:	CHROME PLATED
SIZE:	A4	SCALE:	1:10

A

B

C

D