

A

B

C

D

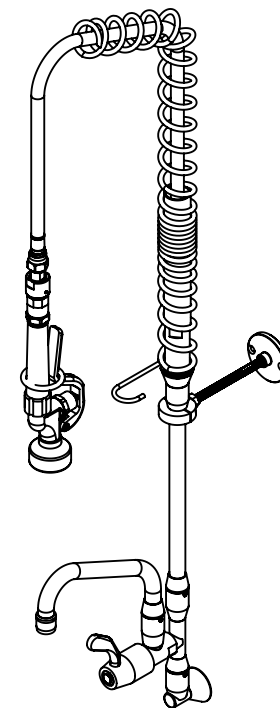
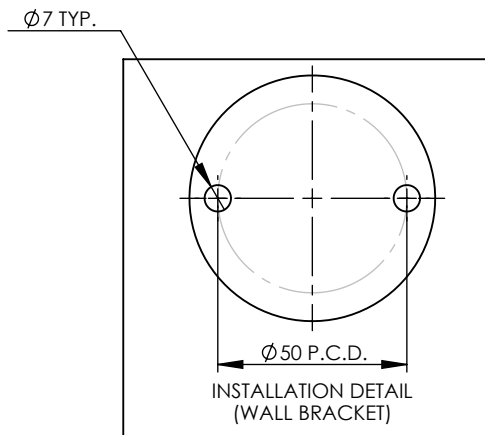
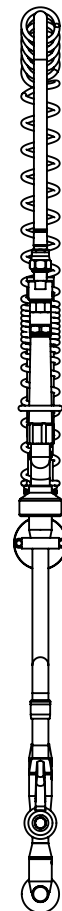
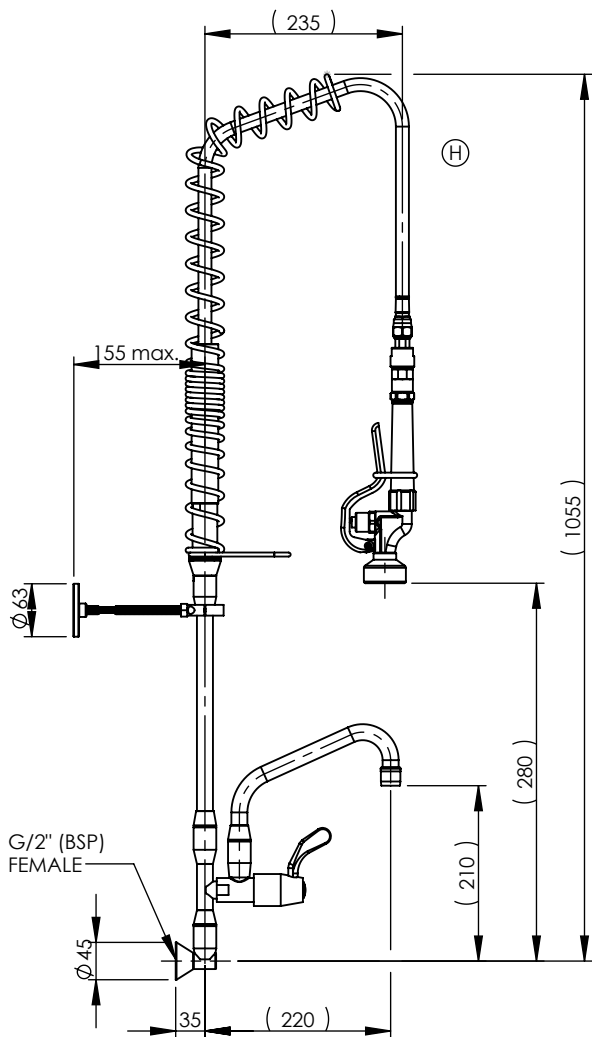

NOTES:

1. SPRAY GUN POSITION DIMENSIONS ARE APPROXIMATE AND REPRESENT A BRAND NEW UNIT.
2. SPRING WILL SAG WITH USE OVER TIME.



GENERAL NOTES:

- DIMENSIONS ARE IN mm's
- DO NOT SCALE OFF DIMENSIONS
- TAPWARE TOLERANCE / 2 (EXCEPT WHERE STATED)
- SAFETY SANITARY AND CARE TOLERANCE / 5 (EXCEPT WHERE STATED)

This drawing is the property of Enware Australia Pty Ltd and may not be reproduced in full or part without the written consent of Enware Australia.

DRAWN	PK
CHECKED	CL
APPROVED	LR



9 Endeavour Rd, Caringbah, NSW, 2229
Ph. +61 2 8536 4000
Email: info@enware.com.au

DRAWING NUMBER: FWS101	REV: H.0
DESCRIPTION: PR WALL RISER W/POT FILLER	
FINISH: CHROME PLATED	SIZE: A4 SCALE: 1:9

A

B

C

D

1

1

2

2

3

3

4

4