

A

B

C

D

1

1

2

2

3

3

4

4

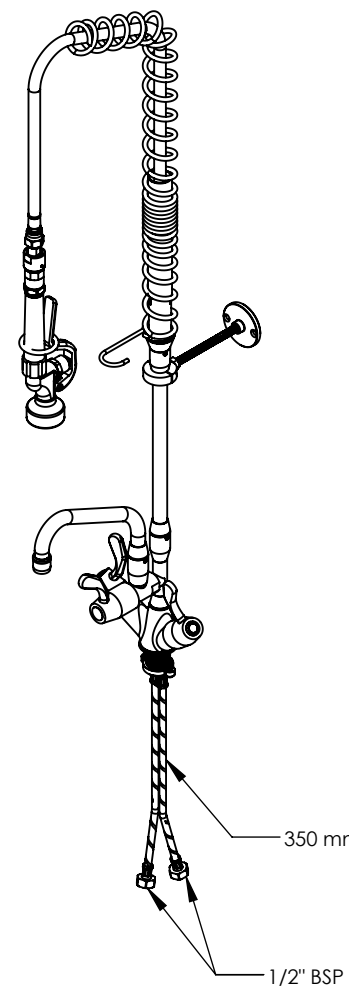
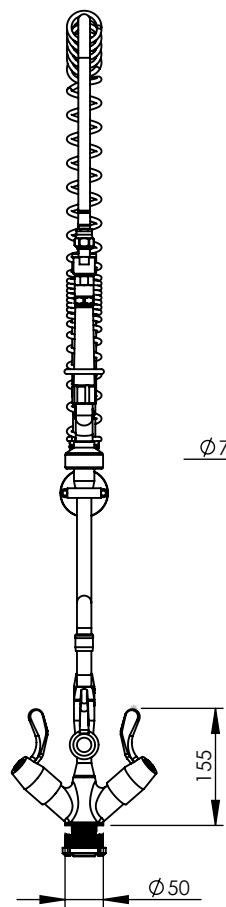
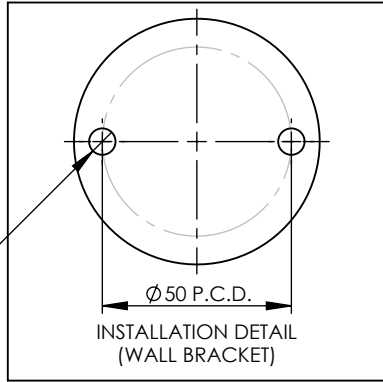
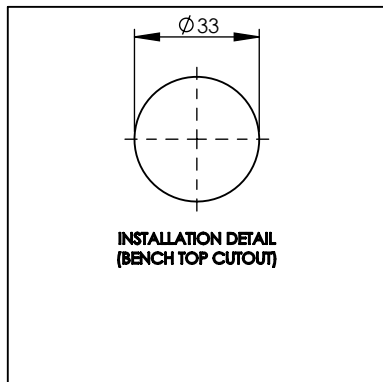
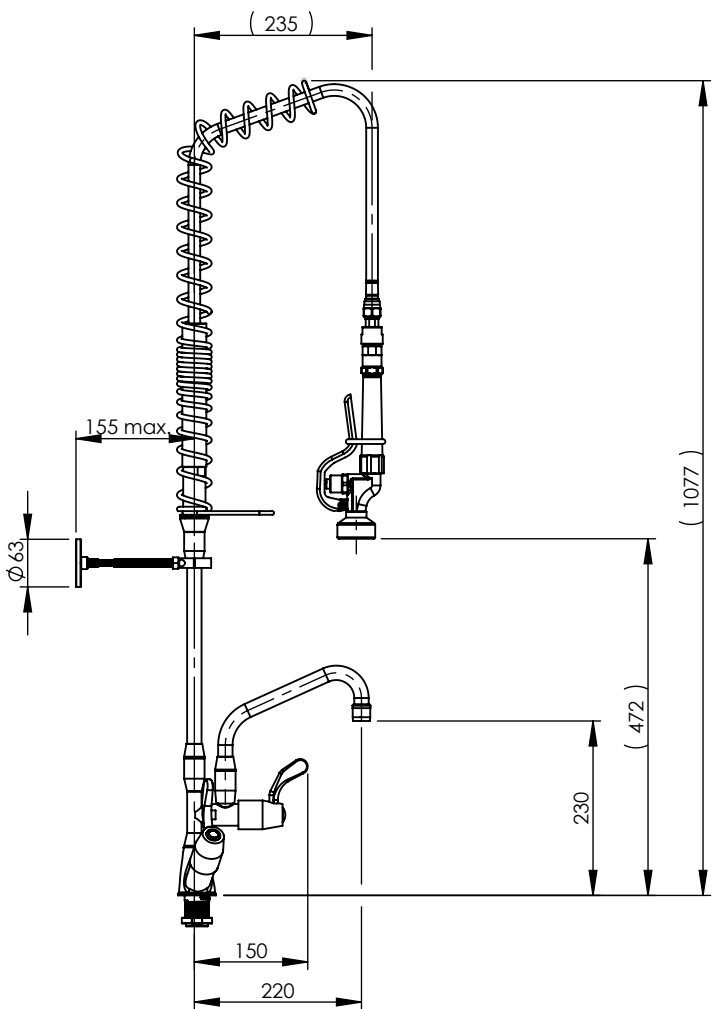
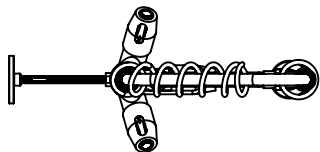

- NOTES:**
1. SPRAY GUN POSITION DIMENSIONS ARE APPROXIMATE AND REPRESENT A BRAND NEW UNIT.
  2. SPRING WILL SAG WITH USE OVER TIME.



**GENERAL NOTES:**  
 - DIMENSIONS ARE IN mm's  
 - DO NOT SCALE OFF DIMENSIONS  
 - TAPWARE TOLERANCE / 2 (EXCEPT WHERE STATED )  
 - SAFETY SANITARY AND CARE TOLERANCE / 5 (EXCEPT WHERE STATED )

This drawing is the property of Enware Australia Pty Ltd and may not be reproduced in full or part without the written consent of Enware Australia.

DRAWN	AC
CHECKED	RA
APPROVED	AK



DRAWING NUMBER: FHS141	REV: J.0
DESCRIPTION: HOB DUAL MIX W/SPRING & POT FILLER	
FINISH: CHROME PLATED	SIZE: A4 SCALE: 1:10

A

B

C

D