

Enware-Oras Cubista Sensor Activated Basin Tap with Temperature Adjuster

ENM6450

Inspired by Cubist Art, this ultra modern touchless tapware with geometric shape and elegant 'look' has been created by top Finnish designer Kirsi Svard. High in quality and easy to use the Cubista is well suited for upmarket applications and is supplied with temperature adjustment for greater user comfort and control. Featuring auto-focus technology and an impulse controlled solenoid for maximum reliability. The Cubista is available in mains or battery powered and is also supplied with mesh strainers and non-return valves for easy installation.

FEATURES

- Auto-focus infrared sensing technology with triangulation for a more consistent, reliable operation
- Improved user friendliness with intelligent activation and after-flow technology
- Impulse controlled solenoid valve provides long battery life
- Single point fixing (not recommended for vandal prone applications)
- Electronics have IP67 rated protection against water and humidity
- 6V Battery operated or 12V Mains powered with 2m lead
- Temperature adjustment lever for greater user comfort and control
- Supplied with WELS 6 Star (5.4lpm) water efficiency rating as standard

Product Codes

ENM6420	Mains Powered
ENM6450	Battery Operated

OPTIONS

- Extended 4.5m lead Mains powered model only order ENMS230

Technical Information

Connection	3/8" & 1/2" BSP Flexi Connector
Recommended Working Pressure	100 - 500kPa
Maximum Operating Temperature [^]	70°C
Sensor Range	Optimally Preset using Auto-Focus technology
Mains Powered	12V transformer with 2m lead Input: 100-240V ~50/60Hz Output: +12V DC 1000mA
Battery Powered	6V Lithium 2CR5 battery Battery life guide: 4 ± 1 years
Protection Class	IP 67
Max Flow Period	2 Minutes

[^] Enware tapware must be installed in accordance with the provisions of, AS/NZS3500 and any relevant local regulations. Installations not complying with AS/NZS3500 may void the product and performance warranty provisions. Heated Water supply AS/NZS 3500.4.

For all sanitary fixtures used primarily for personal hygiene purposes are to deliver heated water not exceeding:

- a) 45°C for early childhood centres, primary and secondary schools, nursing homes or similar facilities for young, aged, care, sick or people with disabilities (43.5°C - NSW Health)
- b) 50°C in all other buildings.

Version: OCT12

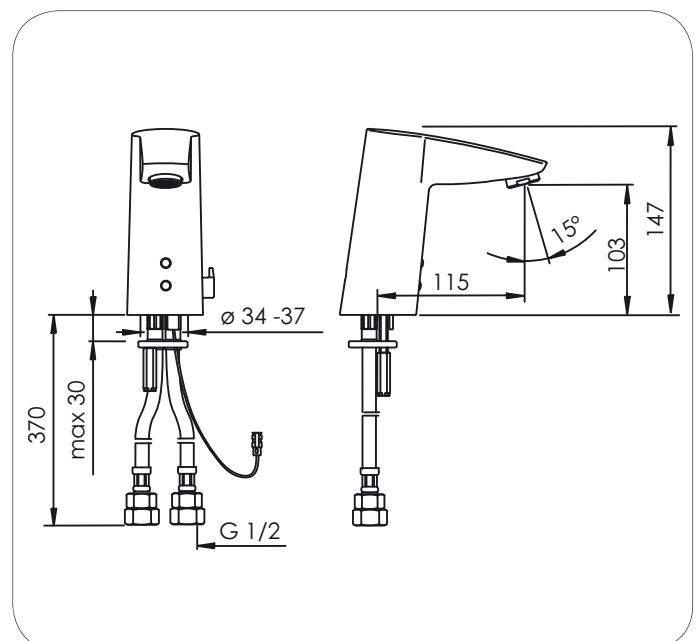

Call 1300 369 273
www.enware.com

Enware Australia Pty Limited
9 Endeavour Rd Caringbah NSW 2229 Australia
Ph: 1300 369 273 Fax: 02 8556 4055

