

# Enware-Oras Electra Integrated Wall Sensor Spout 185mm

**Hygienic and easy to use touchless sensor tap. Suitable for cold or pre-mixed water. Easy to clean and service with all components inside the spout which can be removed with no in-wall components. It is ideal for offices, commercial amenities, health care and education.**

## ENM6186

### FEATURES

- No external parts or battery packs
- Adjustable sensor range and run time using magnetic key
- Low battery warning indicator
- Long battery\* life
- Integrated isolation valve
- Laminar flow aerator minimising the risk of the spread of microbes
- Anti-vandal
- Suitable for cold or mixed water
- Option blue or yellow colour indicator on wall flange
- Suitable for retrofit
- Sensor range 100-200mm. Factory set at 150mm
- Adjustable flow time from 10-300 seconds. Factory set at 120 seconds
- Auto flush setting adjustable from off to 72 hours
- Intelligent afterflow 1-8 seconds. Factory set at 3 seconds  $\pm$  1
- Cleaning mode from 15-60 seconds. Factory set at 30 seconds

\*2x Lithium Battery AA 1.5V

### OPTIONS

Electra Wall Sensor Spout 235mm

**ENM6187**

### Product Codes

**ENM6186** Electra Wall Sensor Spout 185mm

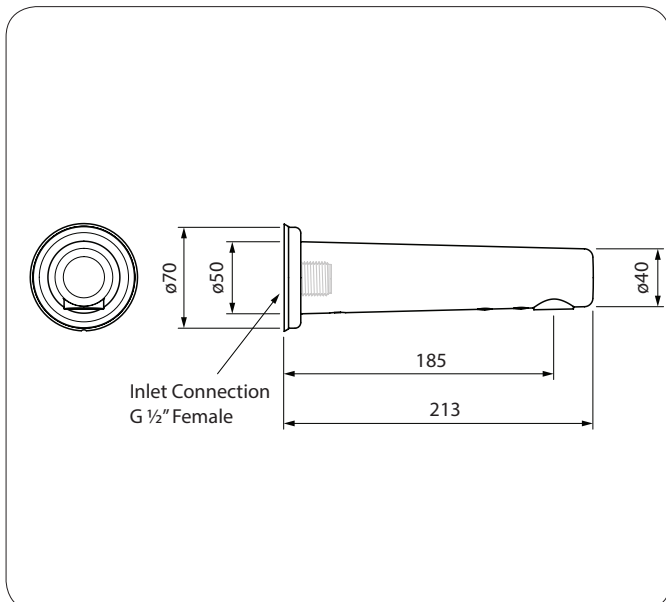

### Technical Information

Inlet Connection	15 mm (1/2") BSP Female
Recommended Working Pressure	100 - 500 kPa*
Recommended Temperature	Cold / Warm up to 43 °C*
Maximum Temperature (For Disinfection Purposes)	70 °C*
Flow Rate	5.5 lpm
Sensor Range	Approx. 150mm ^ (Adjustable 100 - 200 mm)
Intelligent Afterflow Period	2 seconds $\pm$ 1 second ^ (Adjustable 1 - 8 sec $\pm$ 1 sec)
Maximum Continuous Flow Period	120 seconds ^ (Adjustable 10 - 300 sec)
Automatic Flush	OFF ^ (Can be set to flush at intervals 12/24/48/72 hrs, for period 10 - 600 sec)
Protection Class	IP55
Power Supply	Lithium Battery AA 1.5V x 2

\*Enware products are to be installed in accordance with the Plumbing Code of Australia and AS/NZS3500. Thermostatic mixing valves may be required. Reference should also be made to the Australasian Health facility Guidelines (AushFG), ABCB Regulations and Local Building Codes when considering the choice of, and the installation of these products.

^ Settings are Factory Default, adjustable with Magnetic Key  
NOTE: Enware Australia advises:

1. Due to ongoing Research and Development, specifications may change without notice.
2. Component specifications may change on some export models.
3. Refer to Warranty Statement for Warranty details [www.enware.com.au/warranty](http://www.enware.com.au/warranty)

Version: Feb 19

**Call 1300 369 273**  
**[www.enware.com.au](http://www.enware.com.au)**

Enware Australia Pty Limited  
9 Endeavour Rd Caringbah NSW 2229 Australia  
Ph: 02 8536 4000 [info@enware.com.au](mailto:info@enware.com.au)

