

A

B

C

D

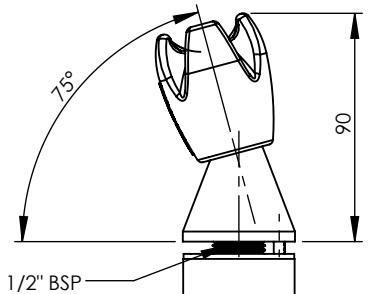
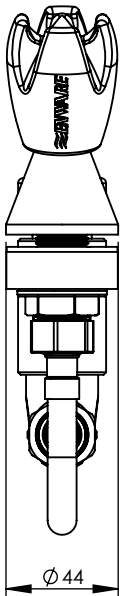
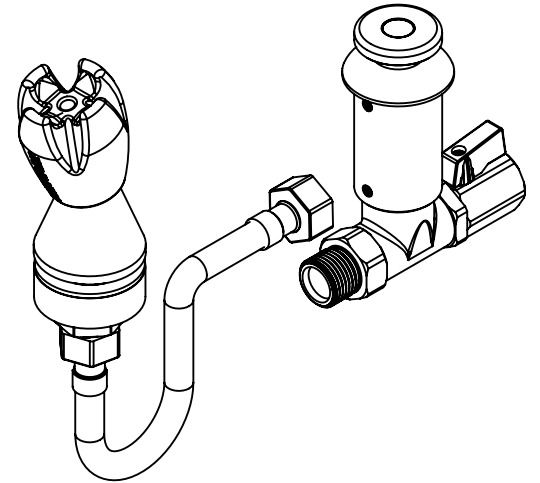
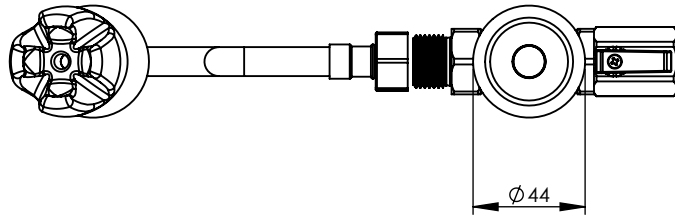

1/2" BSP

CONNECT

300MM FLEX HOSE

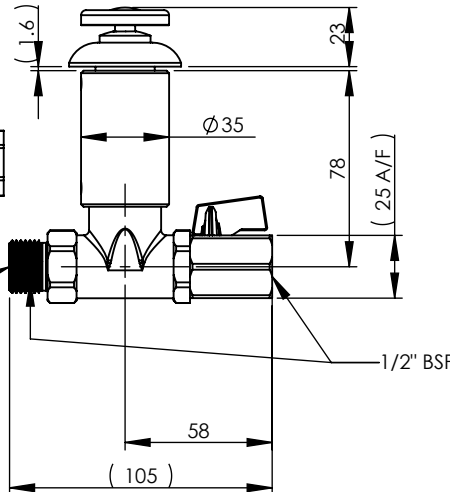

(1.6)

23

Ø 35

78

(25 A/F)

1/2" BSP

58

(105)

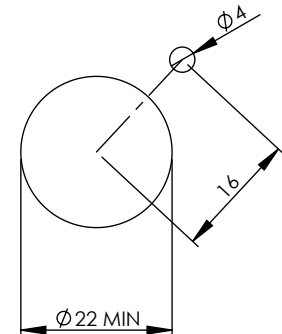

OUTLET CUTOUT
CHECK LOCK PIN ORIENTATION
AND DESIRED POSITION BEFORE DRILL

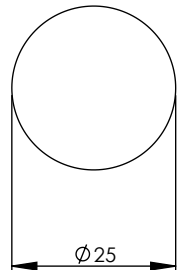

BUTTON CUTOUT



GENERAL NOTES:
 - DIMENSIONS ARE IN mm's
 - DO NOT SCALE OFF DIMENSIONS
 - TAPWARE TOLERANCE / 2 (EXCEPT WHERE STATED)
 - SAFETY SANITARY AND CARE TOLERANCE / 5 (EXCEPT WHERE STATED)

This drawing is the property of Enware Australia Pty Ltd and may not be reproduced in full or part without the written consent of Enware Australia.

| | |
|----------|-----|
| DRAWN | AC |
| CHECKED | LR |
| APPROVED | ENW |

ENWARE
 9 Endeavour Rd,
 Caringbah, NSW, 2229
 Ph. +61 2 8536 4000
 Fax. +61 2 8556 4055

DRAWING NUMBER: **BUB705RB** REV **A.00**
 TITLE: **WA PATT RUBBER GUARD PUSH**
 FINISH:
 SIZE: A4 SCALE: 1:3

A

B

C

D

1

1

2

2

3

3

4

4