

ITEM NO.	PART NUMBER	DESCRIPTION	QTY.
1	892087	BUBBLER-COMplete C/P	1

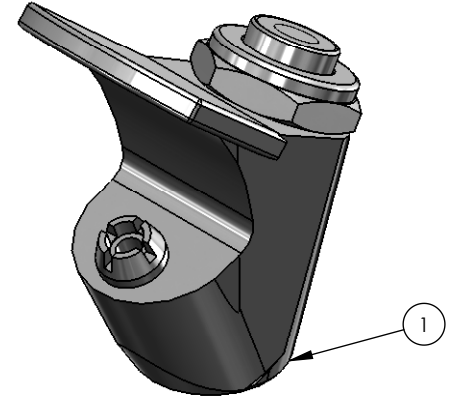
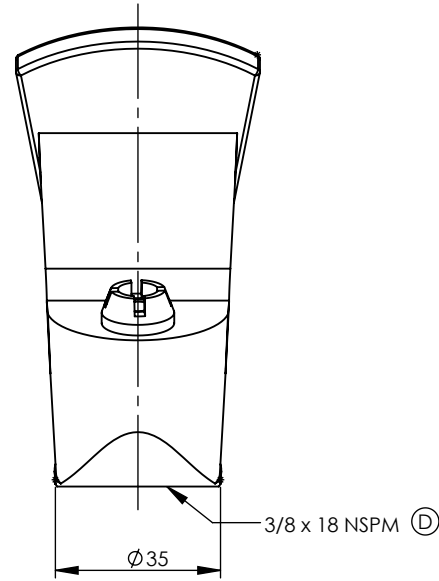
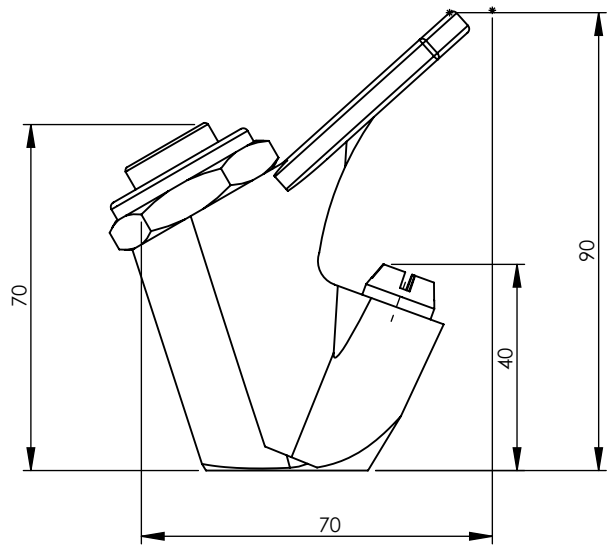
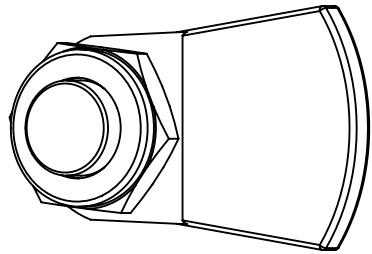

REV	DATE	CN	AMMENDMENTS	MODIFIED BY
A	13/10/06		FIRST ISSUE	
B	25/07/07		3/8" BSP WAS 5/8x18TPI BSP	
C	26/11/07		PART DESCRIPTIONS UPDATED & FINISHING ADDED ©	KN
D	16/06/09		3/8 x 18 NPSM WAS 3/8" BSP ⓓ	SM

GENERAL NOTES:
 REMOVE ALL BURRS AND SHARP EDGES UNLESS OTHERWISE STATED
 DIMENSIONS ARE IN mm's

TOLERANCE EXCEPT WHERE STATED:

NO DECIMAL POINT ± 0.2
 ONE DECIMAL PLACE ± 0.1
 TWO DECIMAL PLACES ± 0.05
 ANGLES ± 1

ENWARE RESERVES THE RIGHT TO AMEND PRODUCT SPECIFICATIONS AND DESIGNS WITHOUT NOTICE.

DRAWN	KN	9 Endeavour Rd, Caringbah, NSW, 2229 Ph. 61-2-9525-9511 Fax. 61-2-9524-8421	
CHECKED			
APPROVED			
TITLE: TYPE 61 BUBBLER OUTLET B/ACTION			
Scale: Not To Scale		Scale: Not To Scale	
MATERIAL:			
FINISH: CHROME PLATED ©			
This drawing is the Copyright of Enware Australia Pty Ltd and may not be reproduced in full or part without the written consent of Enware Australia Pty Ltd		DWG NO.	SHEET 1 OF 1
		BUB290	