

A

B

C

D

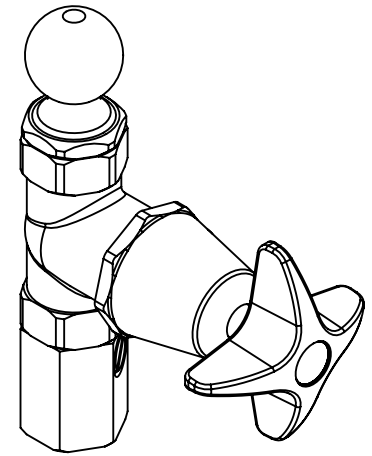
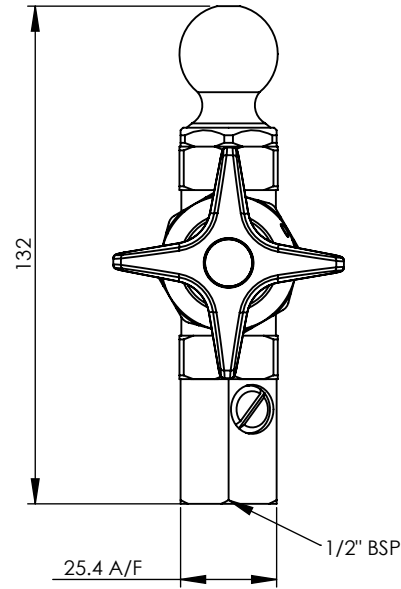
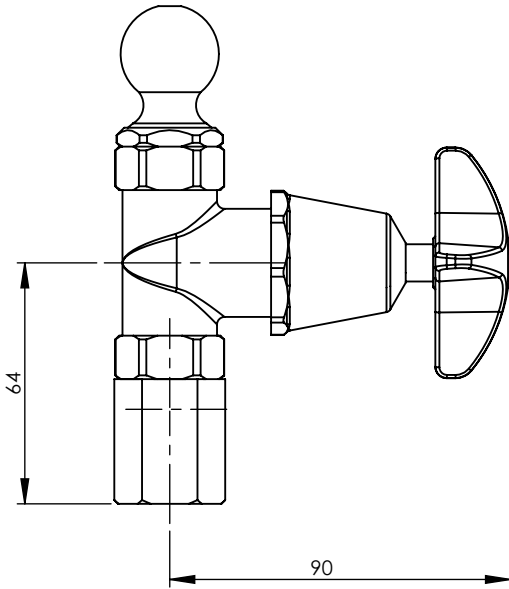
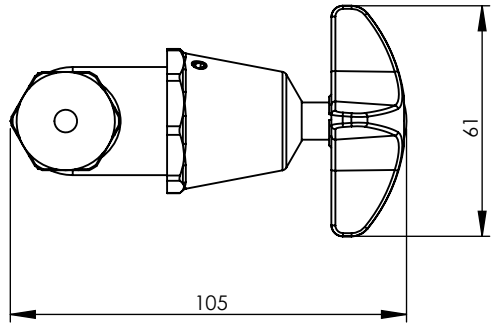

Quality Endorsed Company
 AS/NZS ISO 9001
 LIC No. 1213
 Standards Australia
 ENWARE RESERVES THE RIGHT TO AMMEND PRODUCT SPECIFICATIONS AND DESIGNS WITHOUT NOTICE

GENERAL NOTES:
 - DIMENSIONS ARE IN mm's
 - DO NOT SCALE OFF DIMENSIONS
 - TAPWARE TOLERANCE ± 0.2 (EXCEPT WHERE STATED)
 - SAFETY SANITARY AND CARE TOLERANCE ± 0.5 (EXCEPT WHERE STATED)

This drawing is the property of Enware Australia Pty Ltd and may not be reproduced in full or part without the written consent of Enware Australia.

DRAWN	KN
CHECKED	LR
APPROVED	AC

ENWARE
 9 Endeavour Rd,
 Caringbah, NSW, 2229
 Ph. +61 2 8536 4000
 Fax. +61 2 8556 4055

DRAWING NUMBER: BUB234C		REV B.00
TITLE: T45 UPRIGHT FTN L/GUARD CAM		
FINISH: .	SIZE: A4	SCALE: 1:2

A

B

C

D

1

2

3

4

1

2

3

4