

Type 49 Regulated Fountain Valve Female 15mm

BUB210L

Enware's Australian-made self-closing drinking fountains and bubblers are constructed from dezincification resistant (DR) brass and are WaterMark Licensed to AS/NZS 3718. Featuring a vandal resistant handle, a durable chrome plated finish and an integral adjustable flow regulator allowing onsite control of the flow of water from the outlet. The unique valve design provides an effective, low maintenance mechanism for a range of flow conditions. The tapware and bubblers are serviceable with all wearing components replaceable, thus providing a longer life.

FEATURES

- Vandal resistant design
- Self-closing mechanism
- DR Brass construction
- Integral adjustable flow regulator

OPTIONS

- Push Button - refer to BUB210B
- Cam Handle - refer to BUB210C

Product Codes

BUB210L Lever Handle

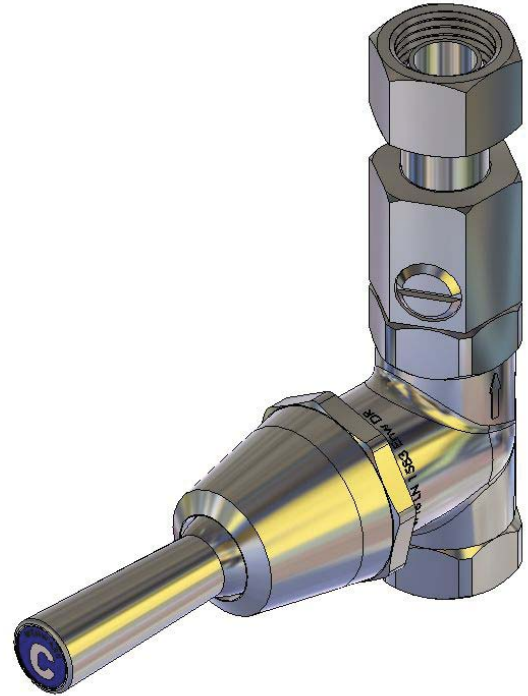

Technical Information

Inlet Connection	15 mm (1/2") BSP
Working Pressure Range	30 - 1200 kPa
Recommended Pressure	100 - 500 kPa
Flow Rate	Supplied standard 8 l/minute with Enware Outlet. Not included under this code.
Operating Temperature Range	0-85°C
Recommended Temperature Range	5-30°C

Enware tapware must be installed in accordance with the provisions of AS/NZS3500 and any relevant local regulations. Installations not complying with AS/NZS3500 may void the product and performance warranty provisions.
The performance of Enware AS/NZS 3718 tapware, in many cases, exceeds the plumbing system design requirements of the Plumbing Code of Australia and AS/NZS 3500.

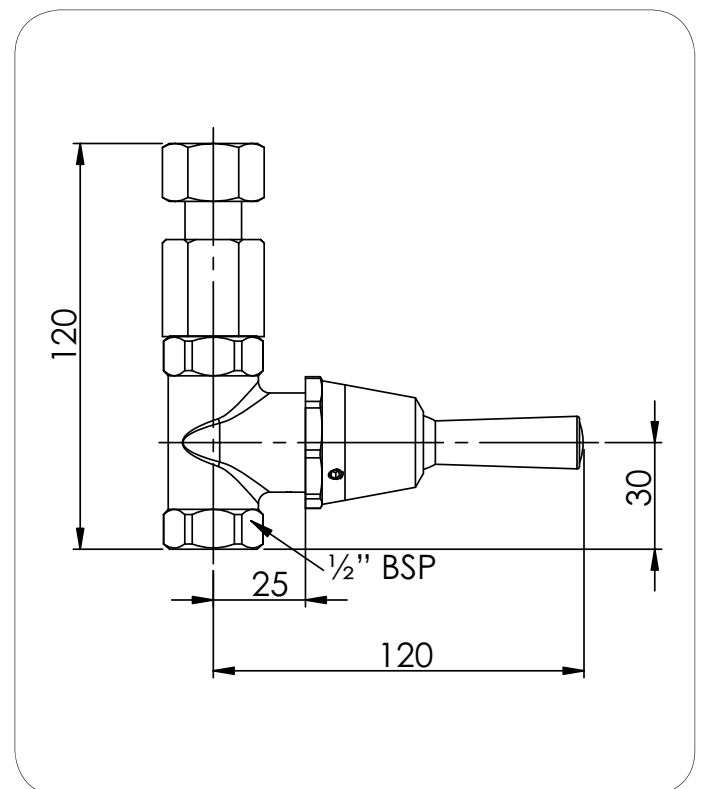

Version: DEC12

Call 1300 369 273
www.enware.com

Enware Australia Pty Limited
9 Endeavour Rd Caringbah NSW 2229 Australia
Ph: +61 2 8556 4000 Fax: +61 2 8556 4055

