

Blueline™ Type 45 Upright Bubbler with Rubber Guard and Optional Bottle Filler

The Enware Blueline™ bubbler and bottle filler range is a new design of drinking bubbler with many new and exclusive features making it practical for school drinking troughs and public spaces.

It is available for Wall Mounting, Upright and Angled installation.

BUB205NC

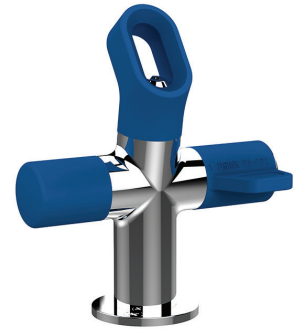

BUB205NCBF

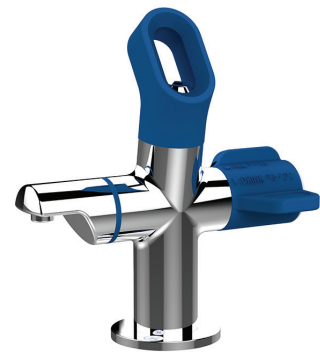

FEATURES

- Easy to turn handle for bubbler
- Handle features directional arrows and braille instruction
- Bright tactile rubber handle grip and turn paddle
- Balance point handle for ease of use
- Bright coloured soft mouth guard protects teeth, gums and lips from accidental damage
- Unique bottle fill function (optional)
- integrated flow control ensures flow is the right height every time
- Integral non-return valve to protect the water supply
- Anti-rotation wall cover flange

OPTIONS

- Bottle Filler

Product Codes

BUB205NC	Blueline™ T45 Upright Bubbler
BUB205NCBF	Blueline™ T45 Upright Bubbler and Bottle Filler



Technical Information

Inlet Connection	1/2" BSP Female
Recommended Working Pressure	100- 500 kPa
Flow Rate	2 l/minute (Bubbler)
	5 l/minute (Bottle Filler)
Operating Temperature Range	5-30 °C

Enware tapware must be installed in accordance with the provisions of AS/NZS3500 and any relevant local regulations. Installations not complying with AS/NZS3500 may void the product and performance warranty provisions.

NOTE: Enware Australia advises: 1. Due to ongoing Research and Development, specifications may change without notice. 2. Component specifications may change on some export models.

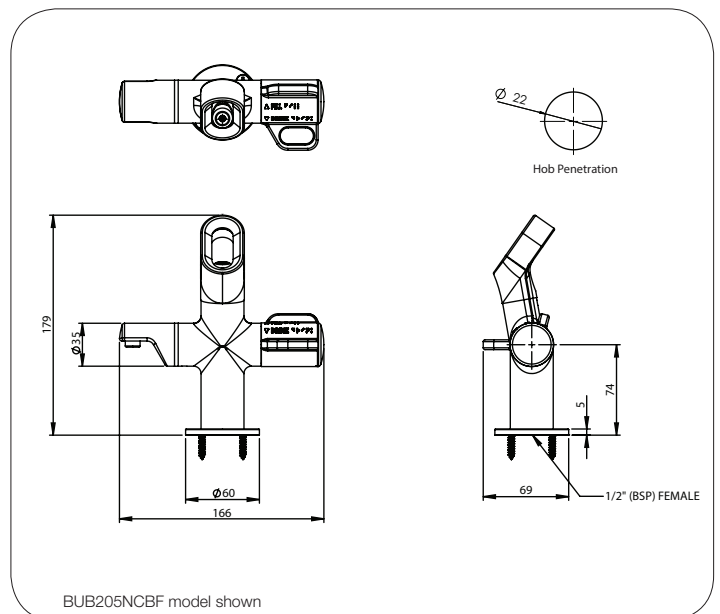

Version: Nov 19

Call 1300 369 273
www.enware.com.au

Enware Australia Pty Limited
9 Endeavour Rd Caringbah NSW 2229 Australia
Ph: 02 8536 4000 info@enware.com.au

