

Type 43 Fountain Valve Outlet Female 15mm

BUB203C

Enware's Australian-made self-closing drinking fountains and bubblers are constructed from dezincification resistant (DR) brass and are WaterMark Licensed to AS/NZS 3718.

The unique valve design provides an effective, low maintenance mechanism for a range of flow conditions. The tapware and bubblers are serviceable with all wearing components replaceable, thus providing a longer life.

FEATURES

- Vandal resistant design
- Durable chrome plated finish
- Integral adjustable flow regulator
- DR Brass construction
- Self-closing mechanism

OPTIONS

- Lever Handle and Push Button - Request when ordering

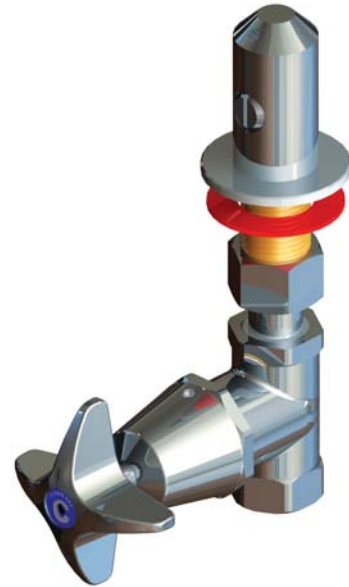

Product Codes

BUB203C Cam Handle

Technical Information

Inlet Connection	15mm 1/2" BSP
Recommended Working Pressure	100- 500 kPa
Flow Rate	2-2.5 l/minute (adjustable)
Maximum Operating Temperature	5-30 °C

Enware tapware must be installed in accordance with the provisions of AS/NZS3500 and any relevant local regulations. Installations not complying with AS/NZS3500 may void the product and performance warranty provisions. The performance of Enware AS/NZS 3718 tapware, in many cases, exceeds the plumbing system design requirements of the Plumbing Code of Australia and AS/NZS 3500.

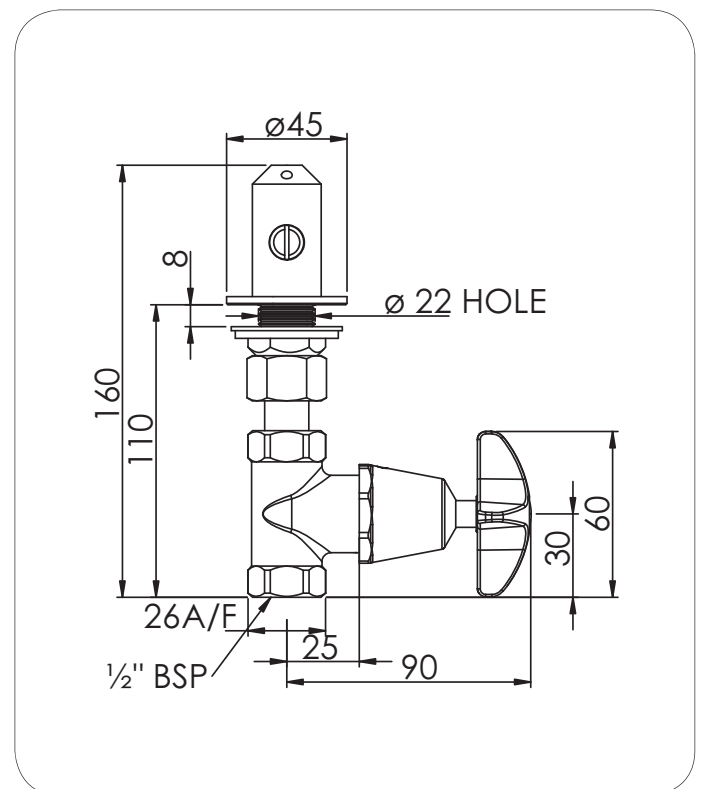

Version: FEB 14

Call 1300 369 273
www.enware.com.au

Enware Australia Pty Limited
9 Endeavour Rd Caringbah NSW 2229 Australia
Ph: +61 2 8556 4000 Fax: +61 2 8556 4055

installing confidence