

Emergency Wall Mounted Hand Operated Deluge Shower

Enware's emergency safety showers assist in the flushing of contaminants from the body with a deluge of flushing fluid

EW1050

Designed and manufactured in Australia. Stainless steel construction provides superior durability and reliability.

FEATURES

- Independently tested for compliance to ANSI Z358.1 and AS4775
- Stainless steel pipe work
- Stainless steel stay open ball valve
- Stainless steel 200mm (8") shower head
- Stainless steel impeller with drenching spray pattern
- Stainless steel pull rod activated shower



ADDITIONAL OPTIONS

- Audio/Visual alarms for alerts
- Flow switch to activate alarms and lights
- Proximity switches an alternative to flow switches
- Thermal relief valve to remove built-up hot water in pipes
- Insulated pipe work to moderate water temperature build up
- Anti-freeze valve for cold weather climates helps prevent water freezing
- Pressure relief valve
- NPT Flange connectors
- Custom manufacturing & design
- Signage compliant to AS1319

Product Codes

EW1050	Standard Brushed Stainless Steel Finish
EW1050GR	Green Powder Coated Finish
EW1050OR	Orange Powder Coated Finish
EW1050YE	Yellow Powder Coated Finish
EW1050WH	White Powder Coated Finish



Technical Information

Inlet Connection	25 mm (1") BSP
Water Supply Line Size	DN25mm (1") nominal size
Working Pressure - to achieve Australian Standard ANSI Z358.1-2004 compliance	210 kPa Caution should be taken when pressure exceeds 550 kPa (80 psi)
Minimum Flow Requirements	75.7 lpm (20 US gpm)
Minimum Working Pressure or for applications not requiring Australian Standard ANSI Z358.1-2004	40 kPa (5.7 psi) [Safety showers are flow volume dependent and the line size needs to be hydraulically calculated.]
Weight	3kg
Dimensions	820 x 220 x 210mm

Installation of emergency showers, eye and eye/face wash equipment shall be in accordance with AS/NZS4775-2007 or ANSI Standard Z358.1 - whichever is applicable to the installation. Enware Australia advises:

- Due to ongoing Research and Development, specifications may change without notice.
- Component specifications may change on some export models.

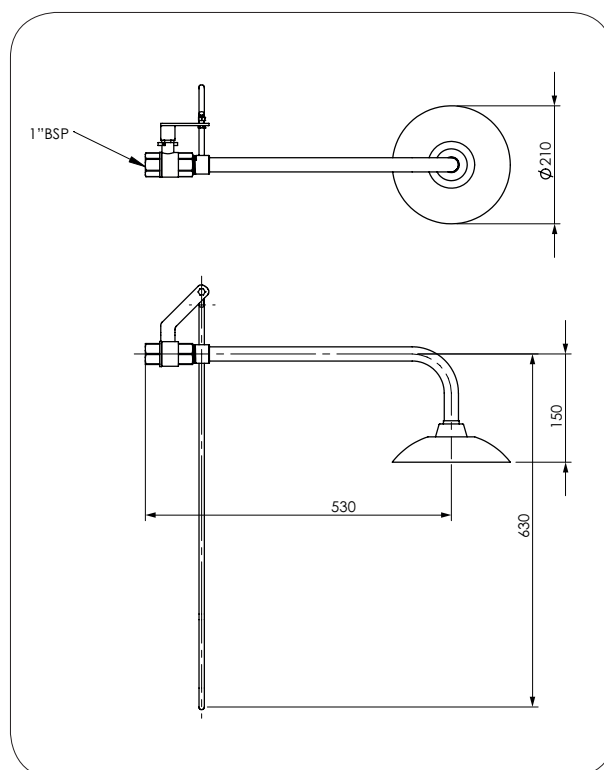

Version: May 18

Call 1300 369 273
www.enware.com.au

Enware Australia Pty Limited
9 Endeavour Rd Caringbah NSW 2229 Australia
Ph: 02 8536 4000 info@enware.com.au



A range of spare parts are available to maintain equipment and replacement of damaged parts.

Description

1	Shower Ball Valve 1"	ESP006
2	Pull Handle To Activate Shower	ESP008
3	Setscrew 1/4 BSWX3/4 SS	672459
4	Nut 1/4 BSW SS Nyloc	672329
5	Inspection Tag	ESS521
6	Shower Arm And Rose	794373
7	Handle to Suit 1" Ball Valve	792574
8	Shower Outlet Impeller Disc	792251
9	Screw Csk 3/16 Bsw x1/2 S/S	672452

