

A

B

C

D

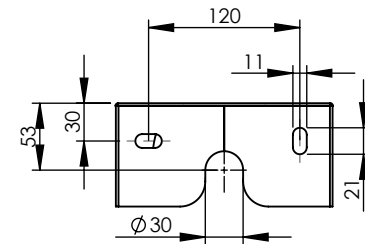
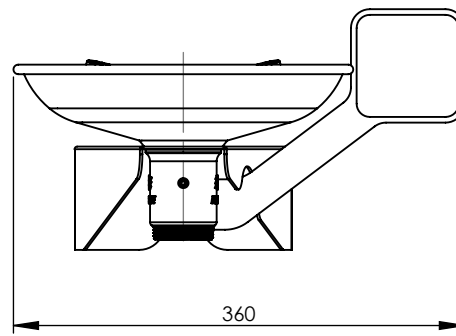
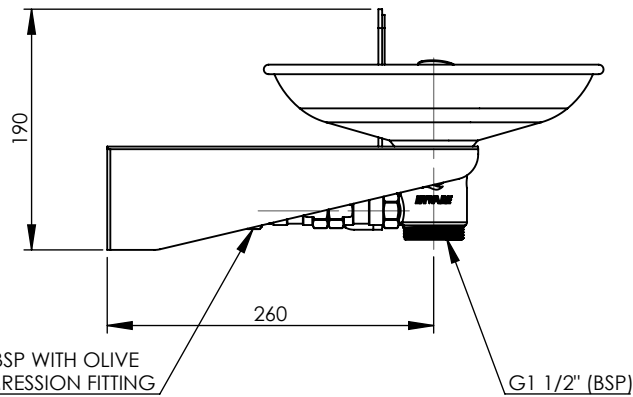
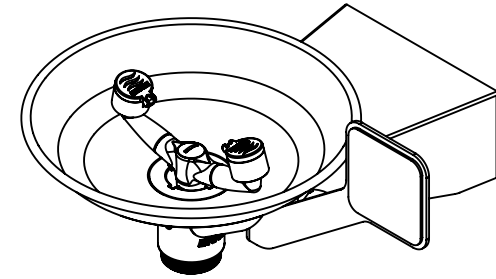
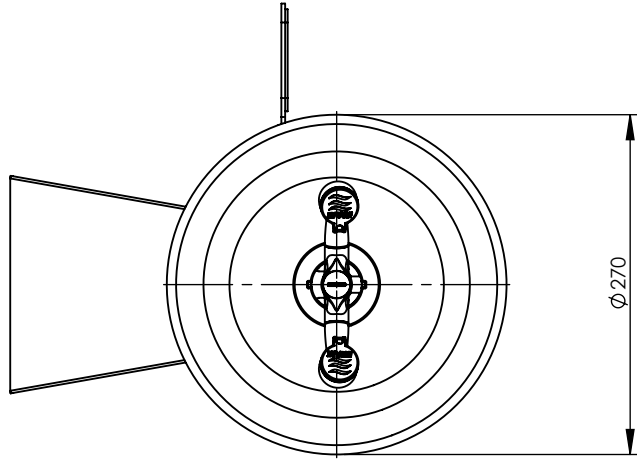

BRACKET MOUNTING DETAILS

1/2" BSP WITH OLIVE COMPRESSION FITTING

G1 1/2" (BSP)

GENERAL NOTES:
 - REMOVE ALL BURRS AND SHARP EDGES UNLESS OTHERWISE STATED
 - ALL THREADS TO BE CHAMFERED
 - DIMENSIONS ARE IN mm's
 - DO NOT SCALE OFF DIMENSIONS

DRAWN CL
 CHECKED CL
 APPROVED LR



9 Endeavour Rd,
 Caringbah, NSW, 2229
 Ph. 61-2-9525-9511
 Fax. 61-2-9524-8421

TOLERANCE EXCEPT WHERE STATED:
 NO DECIMAL POINT ± 2
 ONE DECIMAL PLACE ± 1
 ANGLES $\pm 1^\circ$

This drawing is the property of Enware Australia Pty Ltd and may not be reproduced in full or part without the written consent of Enware Australia.



TITLE
SS W/MNTD EYE WASH HND OPERATE

DRAWING NUMBER: **EEE120**

FINISH:

SIZE: A4

SCALE: 1:6

SHEET: 1 OF 2

REVISION

REV.	DATE	ECN	DESCRIPTION	MODIFIED BY
A	10/02/15	4693	FIRST ISSUE	
B	21/04/15	4852	MOUNTING DETAIL ADDED; SUB ASSEMBLY UPDATED	YK

A

B

C

D

1

1

2

2

3

3

4

4